

**ALCEO**  
**VOLCANO**  
Aluminum Sliding System  
TV200

# INDEX

---

## NUMERIQUE

|                           |                          |
|---------------------------|--------------------------|
| ■ ..... P... <b>2-5</b>   | Certificates.            |
| ■ ..... P... <b>6-7</b>   | Technical Specification. |
| ■ ..... P... <b>8-12</b>  | Techno form Data sheet   |
| ■ ..... P... <b>13-20</b> | Beam Statics             |
| ■ ..... P... <b>21-23</b> | Profiles List            |
| ■ ..... P... <b>24-26</b> | Accessories              |
| ■ ..... P... <b>27-31</b> | Profiles                 |
| ■ ..... P... <b>32-39</b> | Cutting List             |
| ■ ..... P... <b>40-48</b> | Sections                 |
| ■ ..... P... <b>49-50</b> | Details                  |
| ■ ..... P... <b>51-52</b> | 3D Drawings              |

**intertek**  
Total Quality. Assured.

## CERTIFICATE OF REGISTRATION

This is to certify that the management system of:  
**Al Dawlia 21 for Producing Coloring Aluminium Profiles**  
 Main Site: Third Industrial Zone – Piece 576 - 6th October City – Egypt  
 has been registered by Intertek as conforming to the requirements of:  
**ISO 14001:2015**  
 The management system is applicable to:  
 Treatment, coating and wholesale of aluminum profiles.

Certificate Number: DBY060747-EMS-01  
 Initial Certification Date: 01 December 2010  
 Date of Certification Decision: 10 March 2018  
 Issuing Date: 10 March 2018  
 Valid Until: 30 November 2019



*Calin Moldovean*  
**Calin Moldovean**  
 President, Business Assurance  
 Intertek Cer ica on Limited, 10A Victory Park, Victory Road, Derby DE24 8Z9, United Kingdom  
 Intertek Certification Limited is a UKAS accredited body under schedule of accredita on no. 014.



In the issuance of this certificate, Intertek assumes no liability to any party other than to the Client, and then only in accordance with the agreed upon Certification Agreement. This certificate's validity is subject to the organization maintaining their system in accordance with Intertek's requirements for system certification. Validity may be confirmed via email at [certification@intertek.com](mailto:certification@intertek.com) or by scanning the code to the right with a smartphone. The certificate remains the property of Intertek, to whom it must be returned upon request.



**intertek**  
Total Quality. Assured.

## CERTIFICATE OF REGISTRATION

This is to certify that the management system of:  
**Al Dawlia 21 for Producing Coloring Aluminium Profiles**  
 Main Site: Third Industrial Zone – Piece 576 - 6th October City – Egypt  
 has been registered by Intertek as conforming to the requirements of:  
**ISO 9001:2015**  
 The management system is applicable to:  
 Treatment, coating and wholesale of aluminum profiles.

Certificate Number: DBY060747-QMS-01  
 Initial Certification Date: 01 December 2010  
 Date of Certification Decision: 10 March 2018  
 Issuing Date: 10 March 2018  
 Valid Until: 30 November 2019



*Calin Moldovean*  
**Calin Moldovean**  
 President, Business Assurance  
 Intertek Cer ica on Limited, 10A Victory Park, Victory Road, Derby DE24 8Z9, United Kingdom  
 Intertek Certification Limited is a UKAS accredited body under schedule of accredita on no. 014.



In the issuance of this certificate, Intertek assumes no liability to any party other than to the Client, and then only in accordance with the agreed upon Certification Agreement. This certificate's validity is subject to the organization maintaining their system in accordance with Intertek's requirements for system certification. Validity may be confirmed via email at [certification@intertek.com](mailto:certification@intertek.com) or by scanning the code to the right with a smartphone. The certificate remains the property of Intertek, to whom it must be returned upon request.



**intertek**  
Total Quality. Assured.

## CERTIFICATE OF REGISTRATION

This is to certify that the management system of:  
**Al Dawlia 21 for Producing Coloring Aluminium Profiles**  
 Main Site: Third Industrial Zone – Piece 576 - 6th October City – Egypt  
 has been registered by Intertek as conforming to the requirements of:  
**OHSAS 18001:2007**  
 The management system is applicable to:  
 Treatment, coating and wholesale of aluminum profiles.

Certificate Number: DBY060747-OHSAS-01  
 Initial Certification Date: 01 December 2010  
 Date of Certification Decision: 01 November 2016  
 Issuing Date: 02 November 2016  
 Valid Until: 30 November 2019



*Calin Moldovean*  
**Calin Moldovean**  
 President, Business Assurance  
 Intertek Cer ica on Limited, 10A Victory Park, Victory Road, Derby DE24 8Z9, United Kingdom  
 Intertek Certification Limited is a UKAS accredited body under schedule of accredita on no. 014.



In the issuance of this certificate, Intertek assumes no liability to any party other than to the Client, and then only in accordance with the agreed upon Certification Agreement. This certificate's validity is subject to the organization maintaining their system in accordance with Intertek's requirements for system certification. Validity may be confirmed via email at [certification@intertek.com](mailto:certification@intertek.com) or by scanning the code to the right with a smartphone. The certificate remains the property of Intertek, to whom it must be returned upon request.





Quali Middle East Association

### MEMBERSHIP CERTIFICATION

This is to certify that

**EXTRUCOAT 21**  
6TH OF OCTOBER CITY, GIZA, EGYPT

Membership Ref.: A043

is a member of the Quali Middle East Association and is a signatory to the policies and procedures related to the membership of the Association.

Period of validity of the certificate: until 31.12.2018

Dubai, 31 December 2017

QUALI MIDDLE EAST ASSOCIATION

Nasir Fahmeed  
General Secretary

Mailing address: Quali Middle East Association  
c/o Dubai Association Centre, ESO-24, T-19, 7<sup>th</sup> Floor  
Sheikh Rashid Tower, Dubai World Trade Centre  
Dubai, United Arab Emirates

P.O. Box 23070, Dubai-UAE  
Phone: +971 4 309 7088  
E-Mail: admin@qualimiddleeast.com  
Internet: www.qualimiddleeast.com

QMEA License No: DAC-0039 issued by Dubai Chamber of Commerce & Industry

### Authorization to use the quality sign



This is to certify that

#### EXTRUCOAT 21 FOR EXTRUDING ALUMINUM PROFILES

Piece Z13-T15, Engineering Square  
Northern Expansions Industrial Zones  
EG - 12566 6th of October City

Licence number: 1604

is authorized to use the quality sign which is shown above according to the REGULATIONS FOR THE USE OF THE QUALICOAT QUALITY SIGN FOR PAINT, LACQUER AND POWDER COATINGS ON ALUMINIUM FOR ARCHITECTURAL APPLICATIONS.

Date of issue of the licence: 11.08.2017  
Period of validity of the licence: until 31.12.2018

Zurich, 31 October 2017

QUALICOAT

Mohammed C. Panam  
President

CERTIFICATION BODY

Josef Schoppig  
AC-Fiduciaire SA



Mailing address:  
QUALICOAT, P.O. Box 1507, CH-8027 Zurich  
Domicile:  
QUALICOAT c/o AC-Fiduciaire SA, Tödistrasse 42, CH-8002 Zurich

Phone: +41 (0)43 305 09 70/79  
Fax: +41 (0)43 305 09 98  
E-mail: info@qualicoat.net  
Internet: www.qualicoat.net

TV200

Sliding System





*Certificate of Approval*

**Extrucoat 21**

is certified as an Approved Applicator to coat  
**Jotun Super Durable**  
 a product from Jotun Powder Coatings

This Company fulfils the requirements set by Jotun Powder Coatings for pre-treatment and application of powder coatings. These include having the necessary equipment, process controls and technical knowledge to comply with Jotun Powder Coatings' standards.



January 01, 2018  
 (Certificate valid for one year from date above)

*[Signature]*  
 Authorised Signatory  
 Jotun Powder Coatings UAE (LLC)



*Certificate of Approval*

**Extrucoat 21**

is certified as an Approved Applicator to coat  
**Jotun Facade**  
 a product from Jotun Powder Coatings

This Company fulfils the requirements set by Jotun Powder Coatings for pre-treatment and application of powder coatings. These include having the necessary equipment, process controls and technical knowledge to comply with Jotun Powder Coatings' standards.



January 01, 2018  
 (Certificate valid for one year from date above)

*[Signature]*  
 Authorised Signatory  
 Jotun Powder Coatings UAE (LLC)



*Certificate of Approval*

**Extrucoat 21**

is certified as an Approved Applicator to coat  
**Jotun Durasol**  
 a product from Jotun Powder Coatings

This Company fulfils the requirements set by Jotun Powder Coatings for pre-treatment and application of powder coatings. These include having the necessary equipment, process controls and technical knowledge to comply with Jotun Powder Coatings' standards.



January 01, 2018  
 (Certificate valid for one year from date above)

*[Signature]*  
 Authorised Signatory  
 Jotun Powder Coatings UAE (LLC)

**Interpon D Approved Applicator**

**Interpon D1000 Series**

**Extrucoat 21 for producing coloring aluminium profiles**  
3<sup>rd</sup> Industrial area, piece 576, 6<sup>th</sup> of October.  
Giza, Egypt.

Has fulfilled AkzoNobel's tests and inspection regarding the pre-treatment, the application, the quality management standards, the procedures and complies with the requirements of the Architectural Range Approved Applicator schedule.

This certificate is effective from  
**17th October 2017 to 16th October 2018**

Approved for Aluminium Alloys AA6063  
Approved for Pre-treatment Type Chrome

Wael Mahmoud  
Regional Export & Marketing Manager  
Near East & East Africa

Date 17/10/2017  
Certification number N° EGY09D1

AkzoNobel Powder Coatings S.A.E

**Interpon.**  
POWDER COATINGS

**AkzoNobel**

**Interpon D Approved Applicator**

**Interpon D2000 Series**

**Extrucoat 21 for producing coloring aluminium profiles**  
3<sup>rd</sup> Industrial area, piece 576, 6<sup>th</sup> of October.  
Giza, Egypt.

Has fulfilled AkzoNobel's tests and inspection regarding the pre-treatment, the application, the quality management standards, the procedures and complies with the requirements of the Architectural Range Approved Applicator schedule.

This certificate is effective from  
**30th October 2017 to 29th October 2018**

Approved for Aluminium Alloys AA6063  
Approved for Pre-treatment Type Chrome

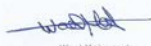
  
Wael Mahmoud  
Regional Export & Marketing Manager  
Near East & East Africa

Date 30/10/2017  
Certification number N° EGY09D2

AkzoNobel Powder Coatings S.A.E

TV200

Sliding System

## SPECIFICATION TECHNIQUE TECHNICAL SPECIFICATION

### PROFILS:

Ce système a été étudié et conçu par Alceo, pour la fabrication de fenêtre à frappe et coulissante. Il utilise les dernières technologies d'assemblage et de fabrication. Ce nouveau système est en conformité avec le standard Européen.

### NORMES PRINCIPALES:

Etudes et production: NF P24-101, NF P24-301, XP P24-400 et 401

Test et classification: NF EN 1026, NF EN 1027, NF EN 12211, NF EN 12207, NF EN 12208, NF EN 12210.

Performances thermiques et acoustiques: NF EN 410, NF EN 673, NF EN ISO 10077-1, PR EN 13947, NF EN ISO 140-4 et NF EN ISO 140-5.

### MATIERE:

Le profil extrudé est en alliage d'aluminium (Al Mg Si) 6060 (norme NF EN 573-3, NF EN 755-1 and 2). Les tolérances sont conformes à la norme NF EN 12020-1 et 2).

### TRAITEMENT THERMIQUE:

T4-T5-T6

### PROTECTION:

Classe d'anodisation :  
classe 15 (15-20 microns)  
Classe 20 (20-25 microns) en option  
L'anodisation est conforme au label qualité QUALANOAD EWWA/EURAS

### ACCESSOIRES:

Tous les accessoires, produits et joints sont conçu pour le système Alceo.  
Utilisation de matériaux de haute qualité.  
Visserie: Acier inoxydable 18/10  
Joint: EPDM  
Autres: Polyamide, Zamack, Fonte d'aluminium

### PROFILES:

This system studied and designed by Alceo is specific for hinged and sliding windows. Using the last technology for fixing and manufacturing operation . This new system is in conformance with French European standard.

### MAIN NORMS:

Study and production: NF P24-101, NF P24-301, XP P24-400 and 401

Test and classification: NF EN 1026, NF EN 1027, NF EN 12211, NF EN 12207, NF EN 12208, NF EN 12210.

Thermic and noise performance: NF EN 410, NF EN 673, NF EN ISO 10077-1, PR EN 13947, NF EN ISO 140-4 and NF EN ISO 140-5.

### MATERIAL:

The extracted profile are in aluminum alloy (Al Mg Si) 6060 (norm NF EN 573-3, NF EN 755-1 and 2). All tolerance are specific norm NF EN 12020-1 and 2).

### THERMICAL TREATMENT:

T4-T5-T6

### PROTECTION:

Anodized class 15 (15-20 microns)  
Class 20 (20-25 microns) in option  
Anodisation will be conforms to the quality label QUALANOAD EWWA/EURAS

### ACCESSORIES:

All accessories, hardware or gaskets are designed for Alceo system.  
High quality material using.  
Screw: Stainless steel 18/10  
Gasket: EPDM  
Other: Polyamide, Zamack, Cast aluminum

## SPECIFICATION TECHNIQUE TECHNICAL SPECIFICATION (suite)

### CONCEPT PRODUIT:

Coulissant, frappe de type traditionnel.

### CADRE FIXE:

Le cadre fixe est de forme tubulaire

### CHASSIS OUVRANT:

Coté et montant central sont de forme tubulaire.

### ASSEMBLAGE:

Cadre dormant : Coupe a 45° assemblé par equerres vissées.

Cadre ouvrant : Coupe a 45° assemblé par equerres vissées.

### VITRAGE :

Simple ou double vitrage, de 6 mm a 22 mm maintenu par des joints en EPDM clippé sur le panneau avec un prise en feuillure minimum de 20mm. Le chassis dot être monté à l'intérieur de la maçonnerie.

### ETANCHEITE:

L'étanchéité est assuré par un joint central en EPDM. Une seconde barrière est incluse dans le dormant au centre du chassis (frappe). ;les joints sont en EPDM, ou Silicone.

Les fenêtres et les portes, assure un excellent drainage.

### CONCEPT PRODUIT:

Sliding windows, window doors , traditional

### FIXED FRAMES:

Fixed frame of form design and tubular section.

### OPENNING FRAMES:

Side and central of form design and tubular section.

### ASSEMBLY:

Door frames: out of cut of mitre by squares with pawn.

Opening: out of cut of mitre by squares with pawn.

### GLAZING:

Simple or insulator of 6 with 22 mm maintained by joints in EPDM and a clipped panel a height minimum of 20mm (bottom of feuillure). The panel must obligatorily be with dimensions interior of construction

### SEALING:

The sealing is guaranteed by a central sealing gasket in EPDM-ASTM tested. A second barrier, constituted by a sealing gasket, is on the flap by the inside overlap. Glazing is done with EPDM sealing gasket or silicone.

The windows and the door producers must guarantee an efficient drainage.

## Material data sheet

Insulating strips of PA 66 GF25

- dry impact resistant -

| No. | Characteristic                          | Reference standard  | Unit              | Samples prepared from extruded insulating strips |   | Injection-moulded samples |
|-----|---|---------------------|-------------------|--|---|---------------------------|
|     |   |                     |                   | Dry <sup>1)</sup>                                | equilibrium <sup>(2)</sup> moisture content | Dry <sup>1)</sup>         |
| 1   | melting temperature                     | EN ISO 11357-3      | °C                | min. 250 <sup>(3)</sup>                          | min. 250 <sup>(3)</sup>                     | min. 250 <sup>(3)</sup>   |
| 2   | density                                 | EN ISO 1183-1 or -3 | g/cm <sup>3</sup> | 1,3 +/- 0,05                                     | 1,3 +/- 0,05                                | 1,3 +/- 0,05              |
| 3   | annealing residue (glass fibre content) | EN ISO 1172         | %                 | 25 +/- 2,5                                       | 25 +/- 2,5                                  | 25 +/- 2,5                |
| 4   | shore hardness D                        | EN ISO 868          |                   | 82 +/- 4 <sup>(4)</sup>                          | 78 +/- 4 <sup>(4)</sup>                     | 84 +/- 2                  |
| 5   | impact strength                         | EN ISO 179-1        | kJ/m <sup>2</sup> | min. 30 or without break <sup>(5)</sup>          | min. 40 or without break <sup>(5)</sup>     | min. 35 <sup>(6)</sup>    |
| 6   | tensile strength                        | EN ISO 527-2 and -4 | N/mm <sup>2</sup> | min. 80 <sup>(7)</sup>                           | min. 50 <sup>(7)</sup>                      | min. 110 <sup>(8)</sup>   |
| 7   | Young's modulus                         | EN ISO 527-2 and -4 | N/mm <sup>2</sup> | min. 4500 <sup>(7)</sup>                         | min. 2000 <sup>(7)</sup>                    | min. 6000 <sup>(8)</sup>  |
| 8   | elongation at break                     | EN ISO 527-2 and -4 | %                 | min. 3 <sup>(7)</sup>                            | min. 7 <sup>(7)</sup>                       | min. 3 <sup>(8)</sup>     |

- 1) Sample water content less than %0,2 by weight
- 2) Fast conditioning acc. to EN ISO °23) 1110C / %50)
- 3) Maximum temperature °300C
- 4) Specimen thickness 2mm, unstacked
- 5) Specimen Typ 2fU (50 mm x 10 mm x 2mm)
- 6) Specimen Typ 1fU (80 mm x 10 mm x 4mm)
- 7) Specimen Typ 1BA
- 8) Specimen Typ 1A

In case of specific questions we gladly offer our individual support.





## Energieeinsparung beginnt mit Technoform

Seit mehr als 30 Jahren entwickeln und produzieren wir für unsere Kunden hochpräzise Isolierprofile, die in Fenstern, Türen und Fassaden aus Aluminium für die thermische Trennung sorgen. Täglich arbeiten wir mit unseren Kunden an neuen, noch besseren Lösungen zur Einsparung von Energie und CO<sub>2</sub>-Emissionen.

- Weltweit haben wir bis heute rund 1,8 Mrd. Meter Isolierstege verkauft
- In ca. 90 Mio. Fenstern sparen sie rund 9 Mrd. kWh Energie pro Jahr und reduzieren damit den CO<sub>2</sub>-Ausstoß erheblich
- Bei 10 Cent Energiekosten pro kWh werden global 900 Mio. € eingespart, die man für andere Dinge sinnvoller ausgeben kann – Jahr für Jahr.

## Energy-Saving starts with Technoform

For over 30 years we have been developing and producing high precision insulating strips for our customers; strips which provide thermal insulation in aluminium windows, doors and facades. Every day we are working with our customers to develop new improved solutions to reduce energy consumption and CO<sub>2</sub>-emissions even further.

- To date we have sold 1.8 billion metres of insulating strips globally.
- In about 90 million windows, they save energy amounting to almost 9 billion kilowatt hours per year and thus reduce CO<sub>2</sub>-emissions considerably.
- Based on a ten euro-cent cost per kilowatt hour, 900 million € are saved globally which can be put to better use. Every year.

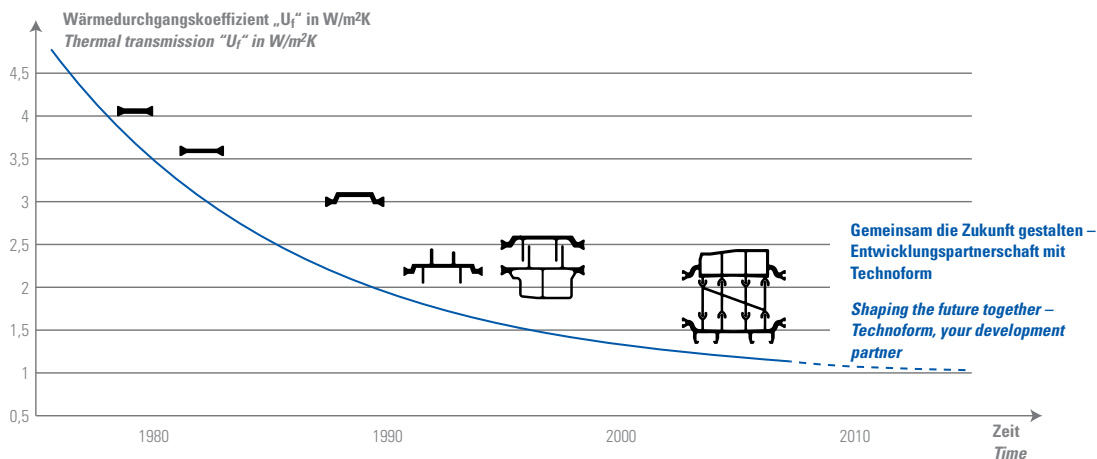

### Vom einfachen Isoliersteg zur komplexen Isolierzone – Entwicklungspartnerschaft mit Technoform

Steigende Anforderungen und neue Entwicklungen stellen uns und unsere Kunden täglich vor neue Herausforderungen. Herausforderungen, die Technoform Bautec seit über 30 Jahren erfolgreich annimmt. Als kompetenter Entwicklungspartner ist es unser Ziel, auch in Zukunft gemeinsam mit unseren Kunden optimale Lösungen für die thermische Trennung in Aluminiumfenstern, -türen und -fassaden zu entwickeln. Nutzen Sie die Entwicklungspartnerschaft mit Technoform Bautec, um führende Systeme am Markt anbieten zu können.

### From straightforward insulating profiles to a complex insulating zone – Technoform your development partner

Ever increasing requirements and cutting-edge developments pose challenges to our customers on a regular basis. Challenges that we at Technoform have been taking on successfully for over 30 years. As a skilled consulting partner it is our aim to continue developing optimum solutions for thermal insulation in aluminium windows, doors and facades together with our customers. Use Technoform Bautec's development partnership to place leading systems on the market.

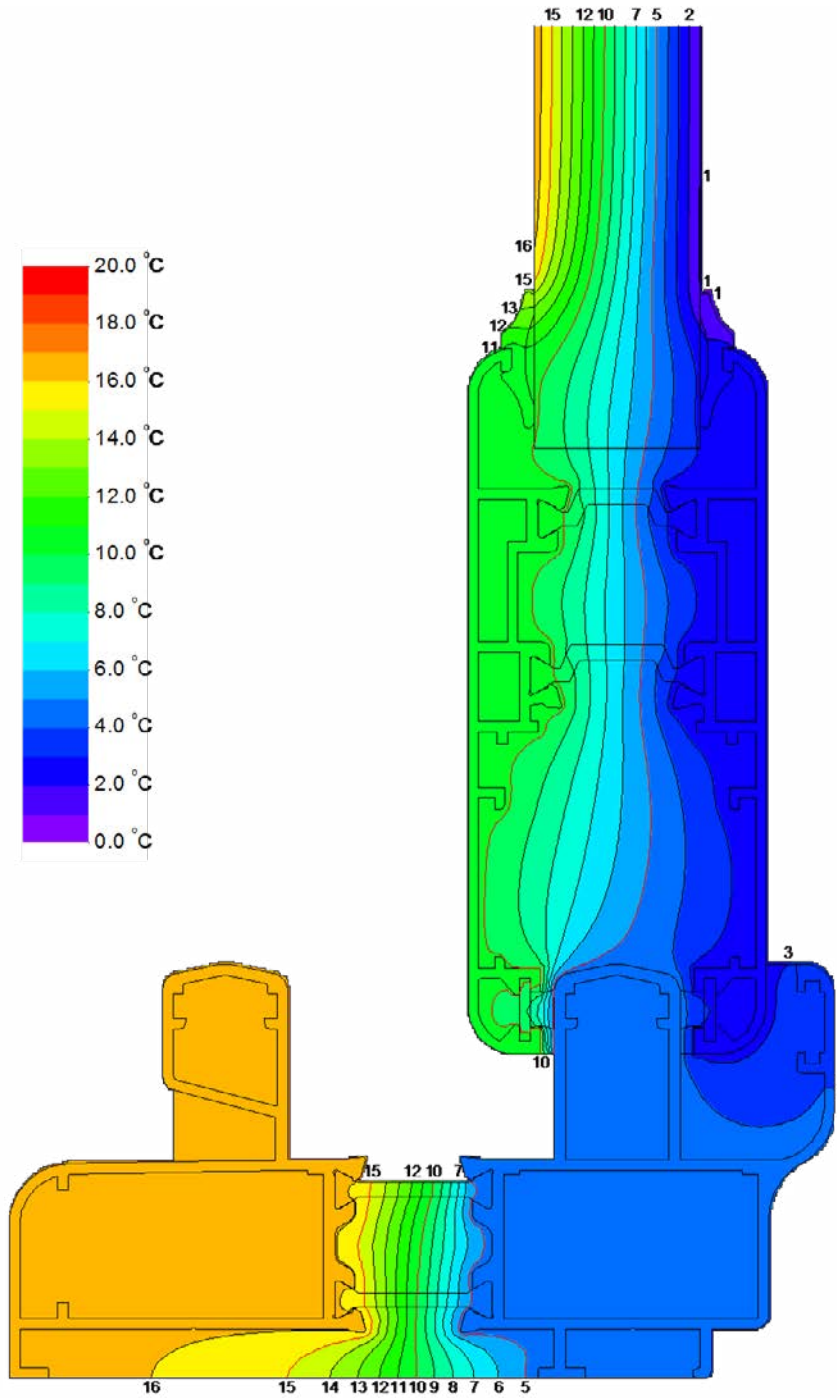

$$U_{fAB} = \frac{\frac{\Phi}{\Delta T} - U_p \cdot b_p}{b_f} = \frac{\frac{17.017}{20.000} - 1.299 \cdot 0.190}{0.131} = 4.60 \text{ W}/(\text{m}^2 \cdot \text{K})$$

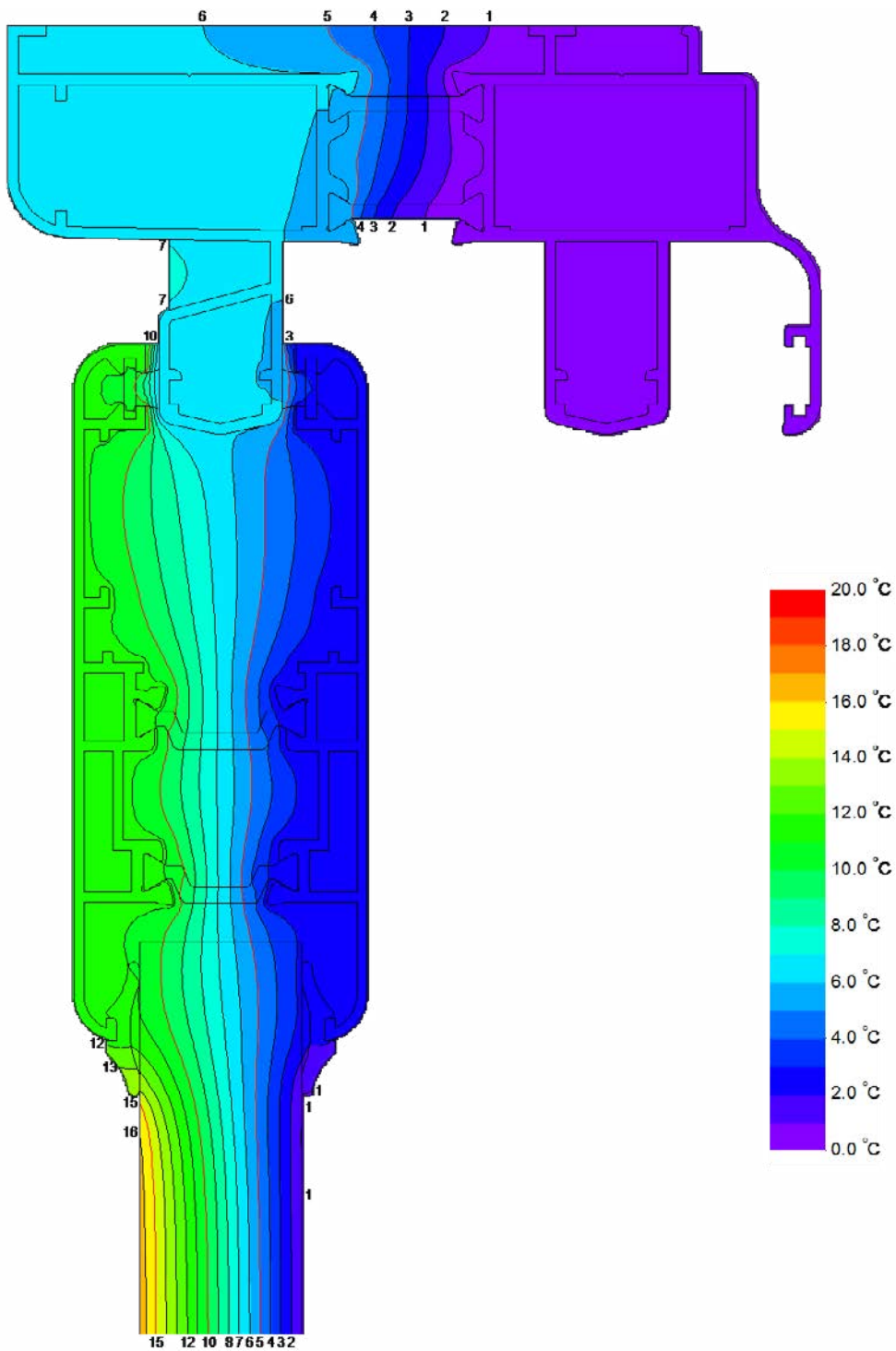

$$U_{I,A,B} = \frac{\frac{\Phi}{\Delta T} - U_p \cdot b_p}{b_f} = \frac{\frac{16.711}{20.000} - 1.299 \cdot 0.190}{0.131} = 4.48 \text{ W}/(\text{m}^2 \cdot \text{K})$$

TV200

Sliding System

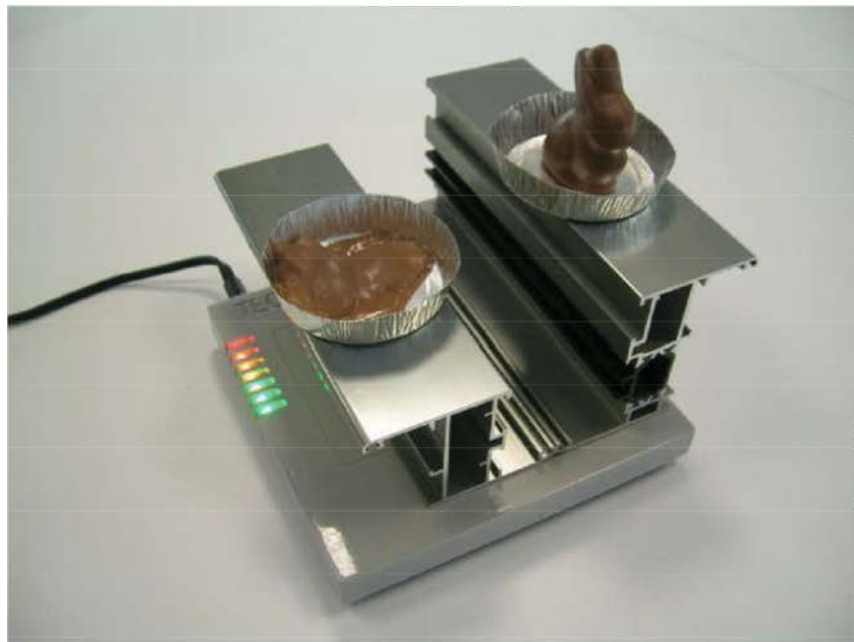

Sliding System

TV200

POWERED BY



**Check For Deflection at the Middle Section of window (Volcano Sliding System)**

Window size is: ( 2200mm Width X 2200m m Height)

Beam Statics - Vertical Germany EN 1991-1-4/NA:2010-12

**Parameter**

Unit (Length):

Installation Height of Element:  m (Upper Edge, Max/ 100 m)

**Calculation**

Ix due to Wind Pressure: 31.5 cm<sup>4</sup> (0.80 kN/m<sup>2</sup>)  
 Ix due to Wind Suction: 31.5 cm<sup>4</sup> (0.80 kN/m<sup>2</sup>)  
**Required Ix-Value: 31.5 cm<sup>4</sup>**

**System**

1-Span Beam  
  2-Span Beam  
 Load Distrib/ Area 1SB  
  Multi-Span Beam

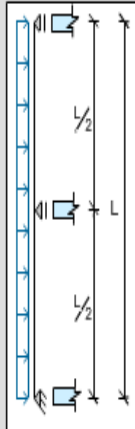
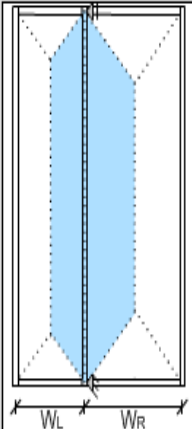
Length (L):  m  
 Field Width Left (wL):  m  
 Field Width Right (wR):  m

Free Ix-Value:  cm<sup>4</sup>

Modulus of Elasticity: 70000 N/mm<sup>2</sup> (Aluminium)

Selected Section: VOLCANO TV2200+DW12312/A 64.0 cm<sup>4</sup>

**Design (Deflection)**

Allowed Glass:  $\text{Min}(15.0\text{mm} | L/200 = 11.0\text{mm}) = 11.0 \text{ mm}$   
 Allowed Beam (Ix):  $\text{Min}(15.0 \text{ mm} | L/200 = 11.0 \text{ mm}) = 11.0 \text{ mm}$

Decisive Glass: 5.4 mm  $\leq$  11.0 mm  
 Decisive Rate of Utilisation: 49.1%

**Deflection Line**

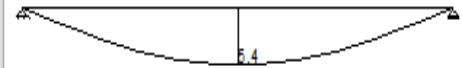

**Moment Diagram**

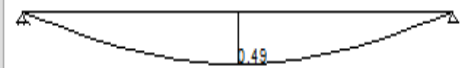

**Shear Diagram**

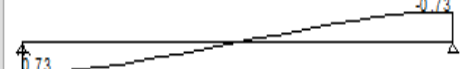

Print   Close

### Beam Statics - Vertical

EN 1991-1-4/NA:2010-12

#### 1. Wind Load Calculation:

Installation Height  $z = 40 \text{ m}$

$$w_e(40\text{m}) = +0.80 \text{ kN/m}^2$$

#### 2. System and Load

E-Modulus:  $E = 70000 \text{ N/mm}^2$

Selected Section: VOLCANO TV2200+DW12312/A,  $I_x = 64.0 \text{ cm}^4$

Load [kN/m]

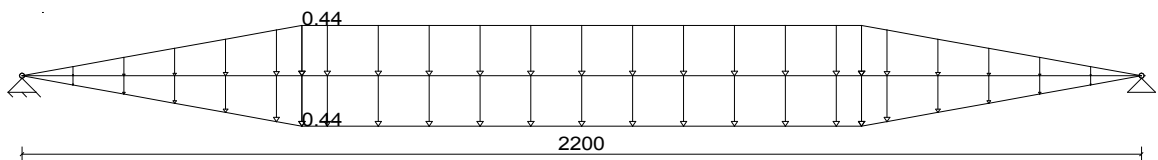

#### 3. Internal Forces

Support Reaction [kN]

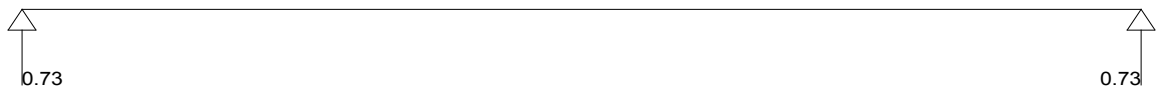

Shear Force [kN]

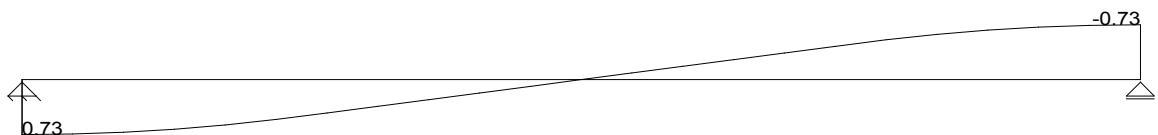

Moment [kNm]

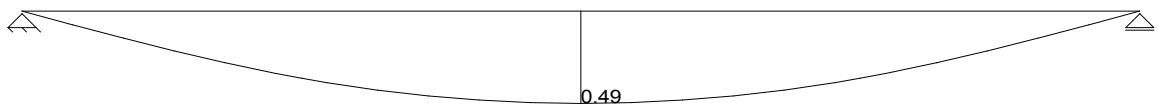

Deflection [mm]

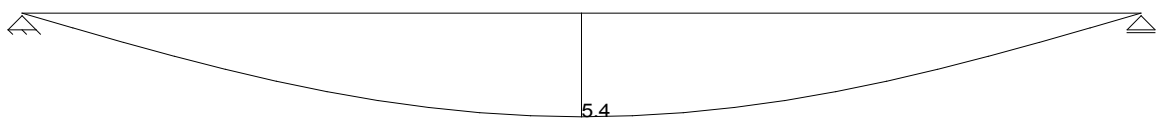

Maximum Deflection: 5.4 mm

#### 4. Design

Selected Section: VOLCANO TV2200+DW12312/A,  $I_x = 64.0 \text{ cm}^4$

Serviceability Limit State:

allowed  $w$  (Glass Edge) =  $\min(15.0 \text{ mm} \mid L_G/200 = 11.0 \text{ mm}) = 11.0 \text{ mm}$

allowed  $w$  (Beam) =  $\min(15.0 \text{ mm} \mid L_B/200 = 11.0 \text{ mm}) = 11.0 \text{ mm}$

Structural Analysis:

current  $w_G = 5.4 \text{ mm} \leq$  allowed  $w_G = 11.0 \text{ mm}$  and current  $w_B = 5.4 \text{ mm} \leq$  allowed  $w_B = 11.0 \text{ mm}$  and current  $I_x = 64.0 \text{ cm}^4 \geq$  required  $I_x = 31.5 \text{ cm}^4$ , Rate of Utilisation  $\eta = 49.1 \%$ , glass edge decisive

| Beam Span  |            |                    |                    |                |  |
|------------|------------|--------------------|--------------------|----------------|--|
| $Z_e$ [m]  | $L_B$ [mm] | allowed $w_B$ [mm] | current $w_B$ [mm] | $\eta_{B}$ [%] |  |
| 40.000     | 2200       | 11                 | 5.4                | 49.1           |  |
| Glass Span |            |                    |                    |                |  |
| $Z_e$ [m]  | $L_G$ [mm] | allowed $w_G$ [mm] | current $w_G$ [mm] | $\eta_{G}$ [%] |  |
| 40.000     | 2200       | 11                 | 5.4                | 49.1           |  |

**Section Properties for (TV+2200DW12312/A):**

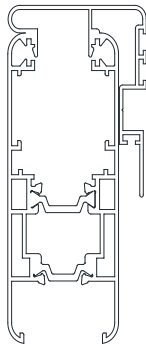

Area: 8.2231  
 Perimeter: 113.6737  
 Bounding box: X: -2.2135 -- 2.5365  
                   Y: -5.1758 -- 4.6242  
 Centroid: X: 0.0000  
               Y: 0.0000  
 Moments of inertia: X: 63.3952  
                       Y: 19.7387  
 Product of inertia: XY: -5.2267  
 Radii of gyration: X: 2.7766  
                       Y: 1.5493  
 Principal moments and X-Y directions about centroid:  
                           I: 64.0123 along [0.9931 -0.1172]  
                           J: 19.1217 along [0.1172 0.9931]



**Check For Deflection at the Middle Section of window (Volcano Sliding System)**

Window size is: ( 2800mm Width X 2400m Height)

Beam Statics - Vertical Germany EN 1991-1-4/NA:2010-12

| Parameter  | Calculation   |
|--|---|
| Unit (Length): <input type="text" value="m"/>  | Ix due to Wind Pressure: 50.0 cm <sup>4</sup> (0.80 kN/m <sup>2</sup> ) |
| Installation Height of Element: <input type="text" value="46.0"/> m (Upper Edge, Max/ 100 m) | Ix due to Wind Suction: 50.0 cm <sup>4</sup> (0.80 kN/m <sup>2</sup> )  |
|  | <b>Required Ix-Value: 50.0 cm<sup>4</sup></b>                           |

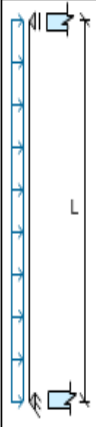
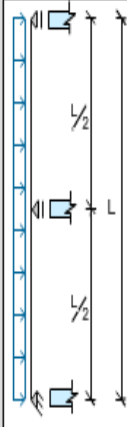
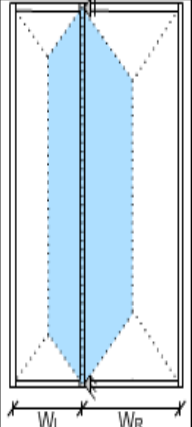

| System  | Design (Deflection)  |
|---|--|
| <input checked="" type="radio"/> 1-Span Beam <input type="radio"/> 2-Span Beam              Load Distrib/ Area 1SB <input type="radio"/> Multi-Span Beam  | Allowed Glass: Min(15.0mm   L/200 = 12.0mm) = 12.0 mm<br>Allowed Beam (Ix Min(15.0 mm   L/200 = 12.0 mm) = 12.0 mm |
| <div style="display: flex; justify-content: space-around;">    </div> | Decisive Glass: 4.9 mm <= 12.0 mm<br>Decisive Rate of Utilisation: 41.2%   |

  

|   |      |
|---|------|
| Length (L): <input type="text" value="2.4"/> m  | Edit |
| Field Width Left (wL): <input type="text" value="1.4"/> m   |      |
| Field Width Right (wR): <input type="text" value="1.4"/> m  |      |
| <input type="radio"/> Free Ix-Value: <input type="text" value="0.0"/> cm <sup>4</sup>   |      |
| Modulus of Elasticity: 70000 N/mm <sup>2</sup> (Aluminium)  | Edit |
| <input checked="" type="radio"/> Selected Section: <input type="text" value="VOLCANO TV2200+DW12312/A 121.4 cm&lt;sup&gt;4&lt;/sup&gt;"/> |      |

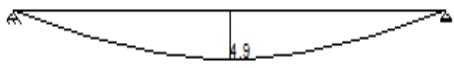

| Deflection Line  |
|--|
|  |

| Moment Diagram   |
|--|
|  |

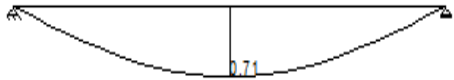
| Shear Diagram  |
|--|
|  |

EN 1991-1-4/NA:2010-12

**1. Wind Load Calculation:**

Installation Height  $z = 46 \text{ m}$

$w_e(46\text{m}) = +0.80 \text{ kN/m}^2$

**2. System and Load**

E-Modulus:  $E = 70000 \text{ N/mm}^2$

Selected Section: VOLCANO TV2200+DW12312/A,  $I_x = 121.4 \text{ cm}^4$

Load [kN/m]

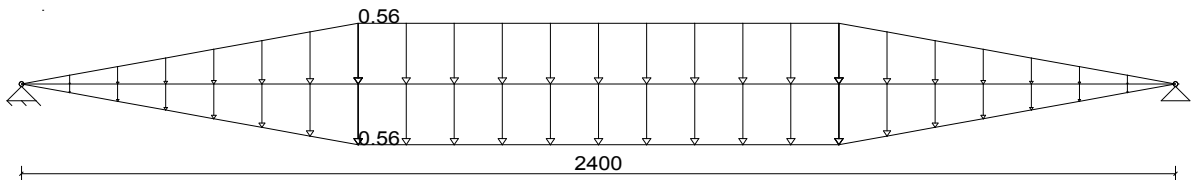

**3. Internal Forces**

Support Reaction [kN]



Shear Force [kN]

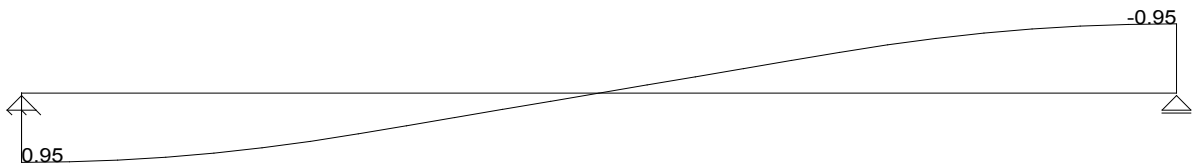

Moment [kNm]

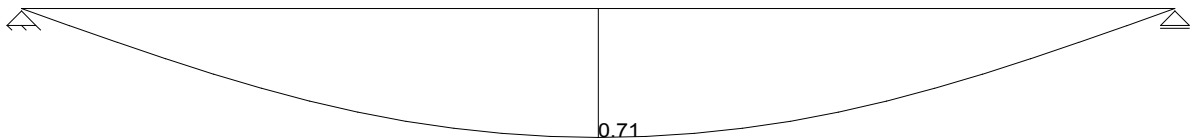

Deflection [mm]

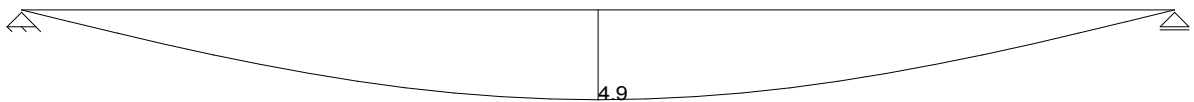

Maximum Deflection: 4.9 mm

#### 4. Design

Selected Section: VOLCANO TV2200+DW12312/A,  $I_x = 121.4 \text{ cm}^4$

Serviceability Limit State:

allowed  $w$  (Glass Edge) =  $\min(15.0 \text{ mm} \mid L_G/200 = 12.0 \text{ mm}) = 12.0 \text{ mm}$

allowed  $w$  (Beam) =  $\min(15.0 \text{ mm} \mid L_B/200 = 12.0 \text{ mm}) = 12.0 \text{ mm}$

Structural Analysis:

current  $w_G = 4.9 \text{ mm} \leq$  allowed  $w_G = 12.0 \text{ mm}$  and current  $w_B = 4.9 \text{ mm} \leq$  allowed  $w_B = 12.0 \text{ mm}$  and current  $I_x = 121.4 \text{ cm}^4 \geq$  required  $I_x = 50.0 \text{ cm}^4$ , Rate of Utilisation  $\eta = 41.2 \%$ , glass edge decisive

| Beam Span     |             |                    |                    |                |  |
|---------------|-------------|--------------------|--------------------|----------------|--|
| $z_e$ [m]     | $L_B$ [mm]  | allowed $w_B$ [mm] | current $w_B$ [mm] | $\eta_{B}$ [%] |  |
| <b>46.000</b> | <b>2400</b> | <b>12</b>          | <b>4.9</b>         | <b>41.2</b>    |  |
| Glass Span    |             |                    |                    |                |  |
| $z_e$ [m]     | $L_G$ [mm]  | allowed $w_G$ [mm] | current $w_G$ [mm] | $\eta_{G}$ [%] |  |
| <b>46.000</b> | <b>2400</b> | <b>12</b>          | <b>4.9</b>         | <b>41.2</b>    |  |

**Section Properties for (TV+2200DW12312/A):**

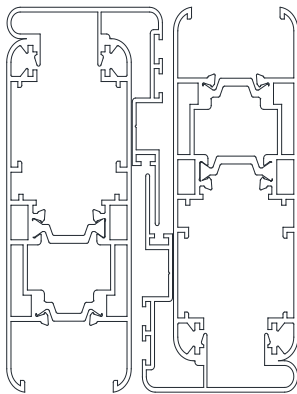



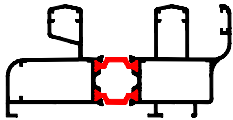
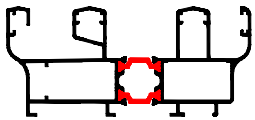
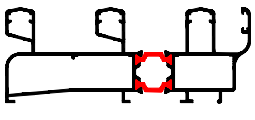
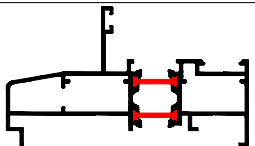
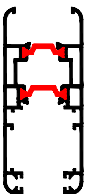
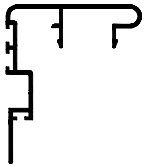
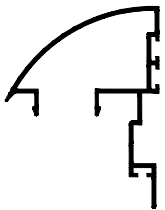
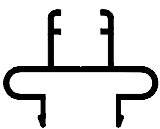









Area: 16.446  
 Perimeter: 227.347  
 Bounding box: X: -4.445 -- 4.445  
                   Y: -4.900 -- 4.900  
 Centroid: X: 0.000  
             Y: 0.000  
 Moments of inertia: X: 128.042  
                       Y: 121.379  
 Product of inertia: XY: -0.331  
 Radii of gyration: X: 2.790  
                       Y: 2.717  
 Principal moments and X-Y directions about centroid:  
                       I: 128.058 along [0.999 -0.049]  
                       J: 121.362 along [0.049 0.999]







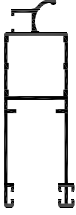

| Profile    | Shape   | Description               | Weight kg/m | lx-x cm <sup>4</sup> | ly-y cm <sup>4</sup> |
|------------|---|---------------------------|-------------|----------------------|----------------------|
| TV 2100    |    | SLIDING 2R FRAME          | 1.849       | 64.14                | 15.861               |
| TV 2101    |    | FRAME 2R WITH FLY SCREEN  | 2.125       | 157.89               | 22.347               |
| TV 2102    |   | SLIDING 3R FRAME          | 2.34        | 98.147               | 20.048               |
| TV 4302    |  | FIXED                     | 1.481       | 40.59                | 6.89                 |
| TV 2200    |  | SASH                      | 1.546       | 34.992               | 14.342               |
| DW 12312/A |  | INTER LOCK PROFILE        | 0.505       | 7.321                | 2.144                |
| DW 12313/A |  | INTER LOCK PROFILE CURVED | 0.564       | 6.28                 | 4.187                |
| DW 12314/A |  | MEETING ADAPTOR           | 0.337       | 0.602                | 1.602                |

TV200

Sliding System







| Profile  | Shape   | Description                | Weight kg/m | Ix-x cm4 | Iy-y cm4 |
|----------|---|----------------------------|-------------|----------|----------|
| DW 12300 |    | DECORATIVE ARCHITRAVE 50MM | 0.369       |          |          |
| DW 12301 |    | DECORATIVE ARCHITRAVE 34MM | 0.295       |          |          |
| DW 12302 |   | FLAT ARCHITRAVE 50MM       | 0.307       |          |          |
| DW 12303 |  | FLAT ARCHITRAVE 34MM       | 0.237       |          |          |
| DW 12304 |  | ARCHITRAVE 50MM            | 0.357       |          |          |
| DW 12305 |  | ARCHITRAVE 34MM            | 0.280       |          |          |
| DW 12308 |  | ROUND ARCHITRAVE 50MM      | 0.365       |          |          |
| DW 12309 |  | ROUND ARCHITRAVE 34MM      | 0.298       |          |          |
| DW 12310 |  | CUREVED ARCHITRAVE 50MM    | 0.355       |          |          |

| Profile  | Shape   | Description                         | Weight kg/m | Ix-x cm <sup>4</sup> | Iy-y cm <sup>4</sup> |
|----------|---|-------------------------------------|-------------|----------------------|----------------------|
| DW 12311 |    | CUREVED<br>ARCHITRAVE<br>34MM       | 0.273       |                      |                      |
| DW 12315 |   | FLY<br>SCREEN                       | 0.655       | 9.224                | 1.925                |
| DW 12316 |  | MEETING<br>ADAPTOR<br>FLY<br>SCREEN | 0.173       | 0.986                | 0.886                |
| DW 12317 |  | GLASS<br>REDUCER<br>12MM            | 0.262       |                      |                      |

| <b>CODE</b>      | <b>DRAWING</b>  | <b>DESCRIPTION</b>           | <b>MATERIAL</b> |
|------------------|---|------------------------------|-----------------|
| WH-OMEGA-05      |    | <i>CREMON HANDEL</i>         | ALUMINIUM       |
| IH-247-05        |    | <i>PORTOGUESE LOCK PLATE</i> | ALUMINIUM       |
| 01-4210          |   | <i>CORNER JOINT</i>          | ALUMINIUM       |
| ALU-575          |  | <i>ALIGNMENT FOR SASH</i>    | ALUMINIUM       |
| PLAST-570        |  | <i>ALIGNMENT FOR SASH</i>    | PVC             |
| ALU-574          |  | <i>ALIGNMENT FOR FRAME</i>   | ALUMINIUM       |
| ANTIDUST-3395-03 |  | <i>ANTI DUST</i>             | ALUMINIUM       |
| PLAST-3331       |  | <i>SHOCK ABSORBER GUIDE</i>  | PLASTIC         |



| <b>CODE</b>  | <b>DRAWING</b>  | <b>DESCRIPTION</b>                 | <b>MATERIAL</b>      |
|--|---|------------------------------------|----------------------|
| <br>SUPRIMO   |    | <i>DOUBLE ROLLER (320 Kg)</i>      | <i>ITALIAN NYLON</i> |
| <br>SUPRIMO  |   | <i>SINGLE ROLLER (160 Kg )</i>     | <i>ITALIAN NYLON</i> |
| <br>SUPRIMO |  | <i>ROLLER FOR FLY SCREEN</i>       | <i>ITALIAN NYLON</i> |
| <br>SUPRIMO |  | <i>ROUND COVER CAP</i>             | <i>PVC</i>           |
| <br>SUPRIMO |  | <i>CORNER JOINT FOR FLY SCREEN</i> | <i>PVC</i>           |
| PL-3495  |  | <i>COVER CAPS</i>                  | <i>PVC</i>           |

| <b>CODE</b> | <b>DRAWING</b>  | <b>DESCRIPTION</b>           | <b>MATERIAL</b> |
|-------------|---|------------------------------|-----------------|
| PB01        |    | <i>BRUSH FOR DOOR 7*7MM</i>  | <i>NYLON</i>    |
| PB02        |    | <i>BRUSH FOR DOOR 7*10MM</i> | <i>NYLON</i>    |
| AVR.03      |   | <i>GLASS GASKET 3MM</i>      | <i>EPDM</i>     |
| AVR.03'     |  | <i>GLASS GASKET 3MM</i>      | <i>EPDM</i>     |
| AVR.04      |  | <i>GLASS GASKET 4MM</i>      | <i>EPDM</i>     |
| AVR.05      |  | <i>GLASS GASKET 5MM</i>      | <i>EPDM</i>     |
| AVR.111     |  | <i>MEETING GASKET</i>        | <i>EPDM</i>     |

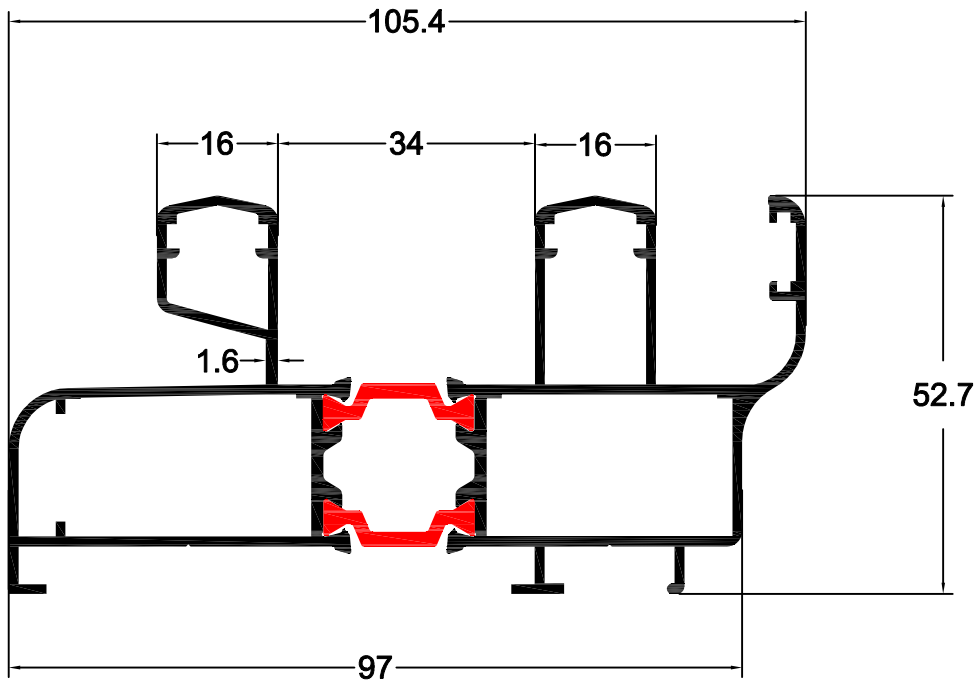

**TV 2100**  
1.849 Kg/m.

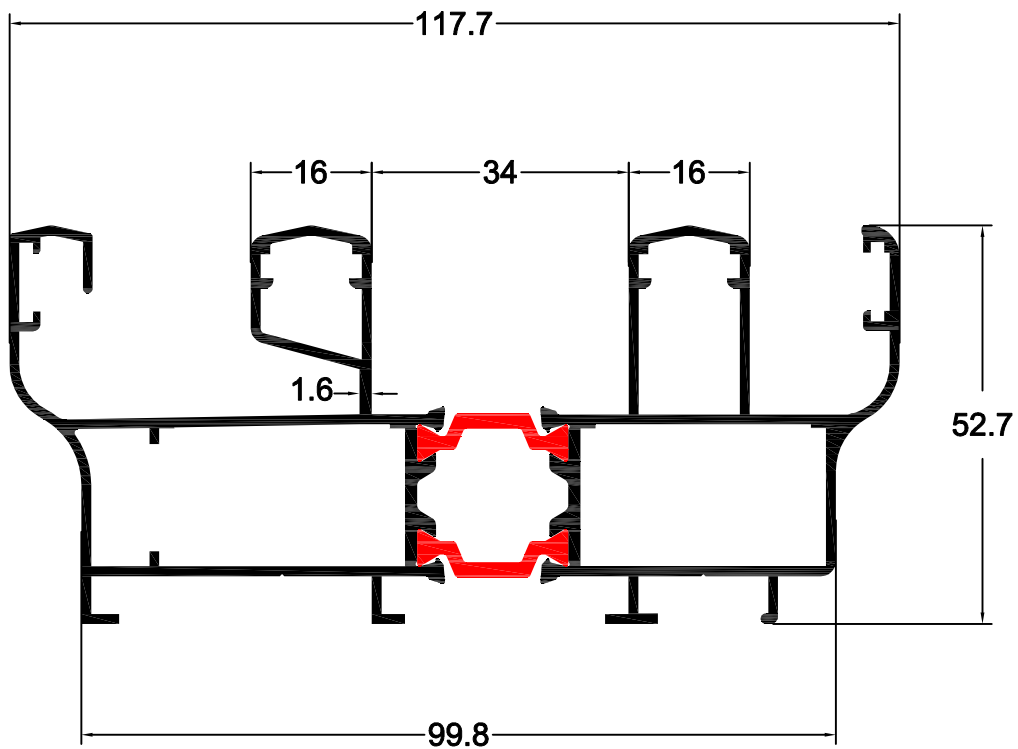

**TV 2101**  
2.125 Kg/m.

TV200

Sliding System

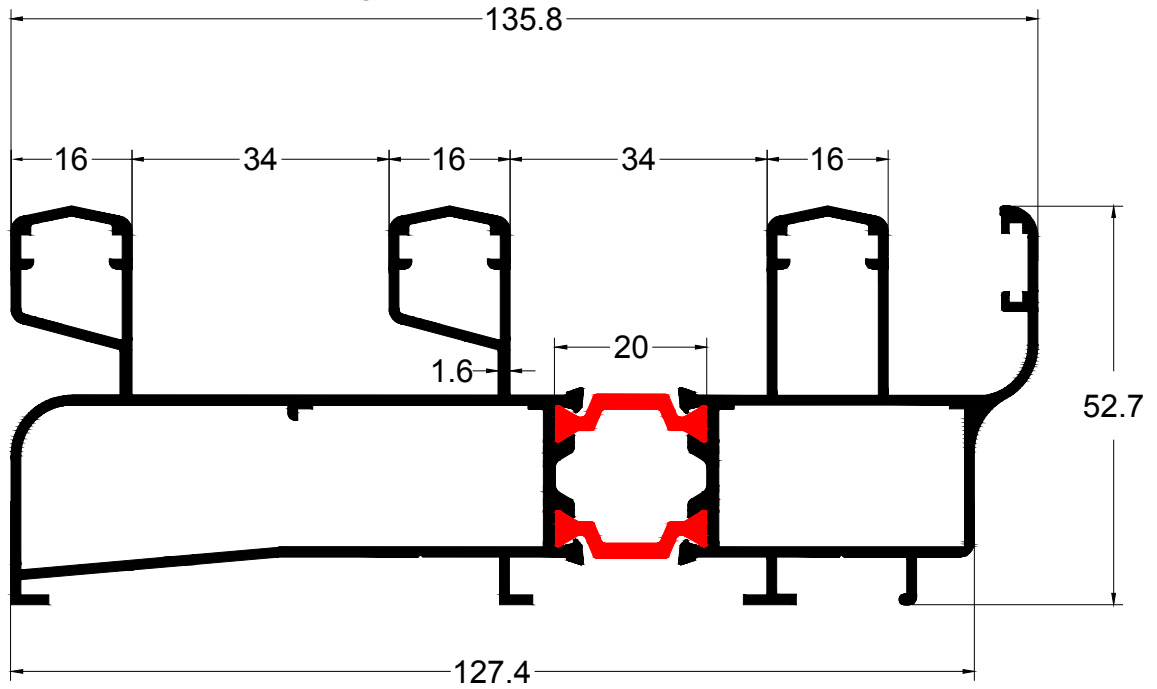

TV 2102  
2.34 Kg/m.

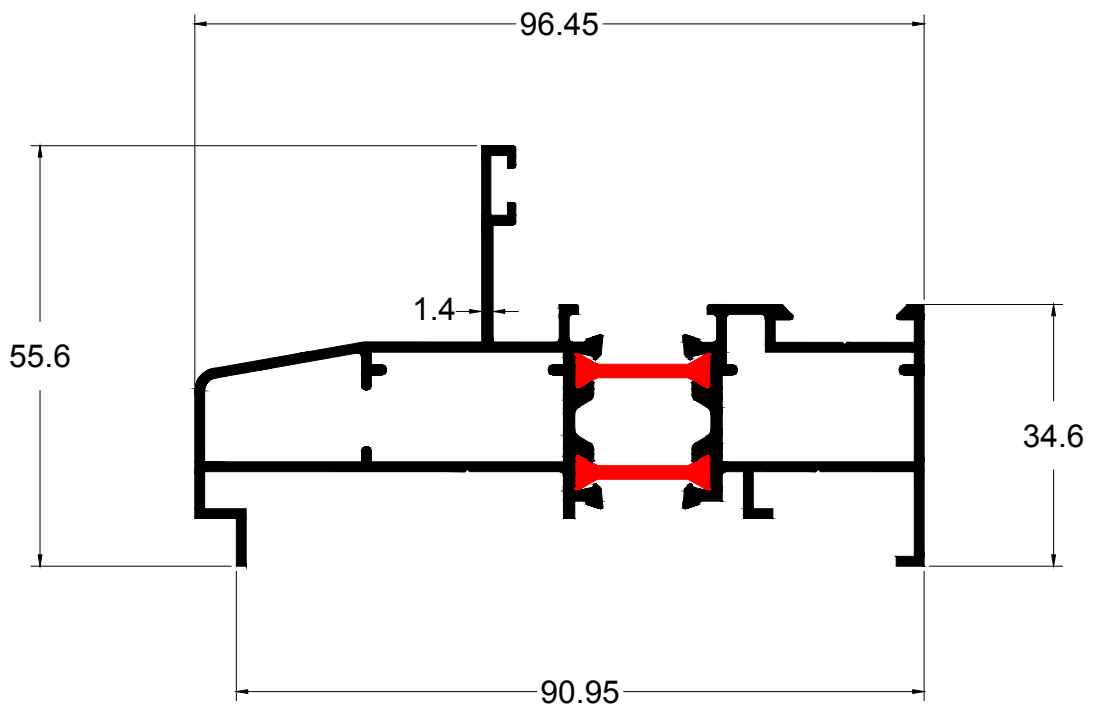

TV 4302  
1.481 Kg/m.

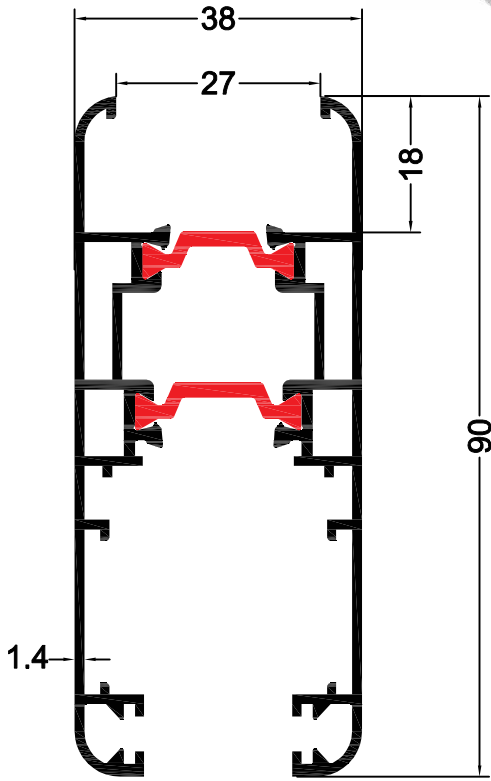

**TV 2200**  
1.546Kg/m.

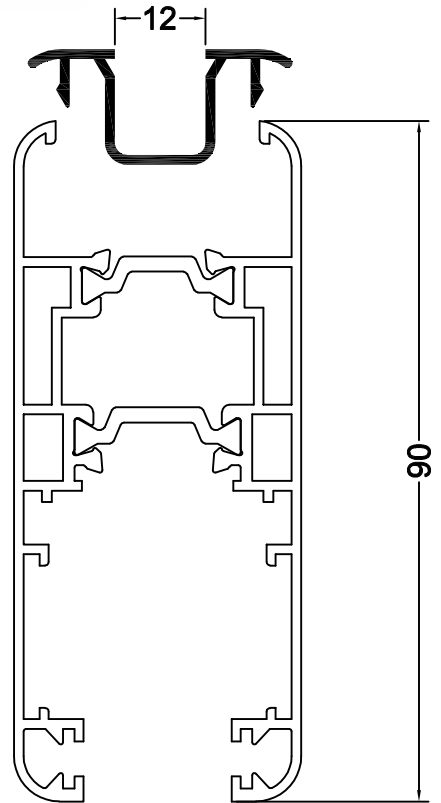

**DW 12317**  
0.262 Kg/m.

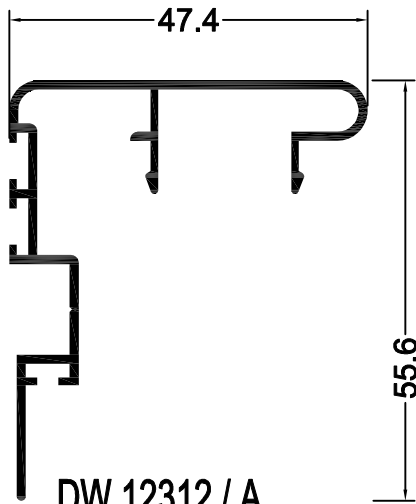

**DW 12312 / A**  
0.505 Kg/m.

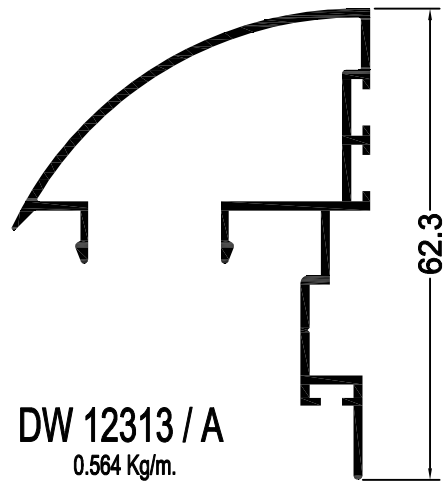

**DW 12313 / A**  
0.564 Kg/m.

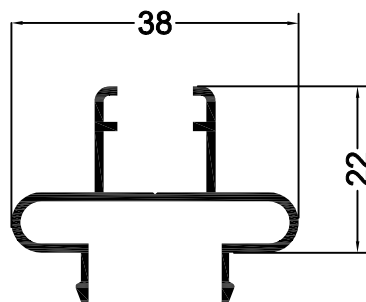

**DW 12314 / A**  
0.337 Kg/m.

TV200

Sliding System

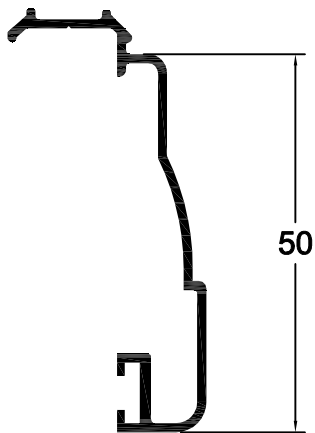

**DW 12300**  
0.369 Kg/m.

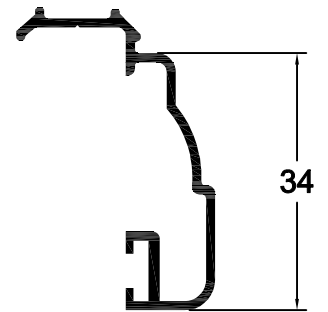

**DW 12301**  
0.295 Kg/m.

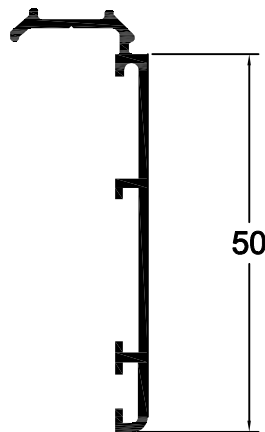

**DW 12302**  
0.307 Kg/m.

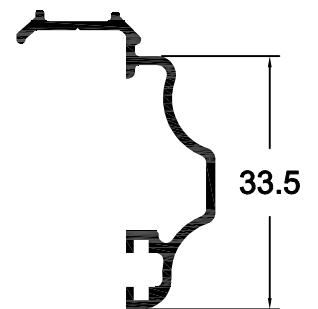

**DW 12305**  
0.280 Kg/m.

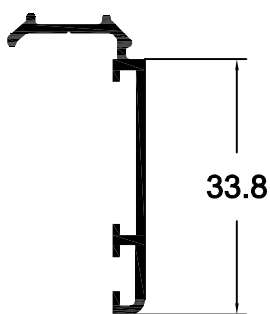

**DW 12303**  
0.237 Kg/m.

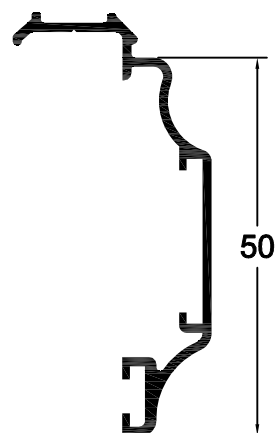

**DW 12304**  
0.357 Kg/m.

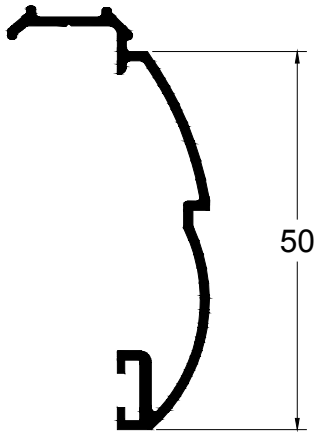

DW 12308  
0.365 Kg/m.

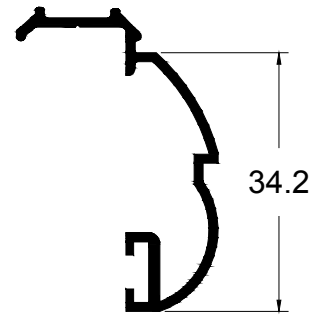

DW 12309  
0.298 Kg/m.

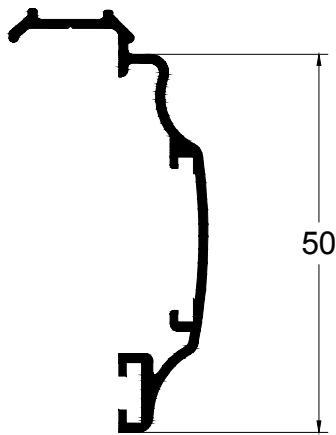

DW 12310  
0.355 Kg/m.

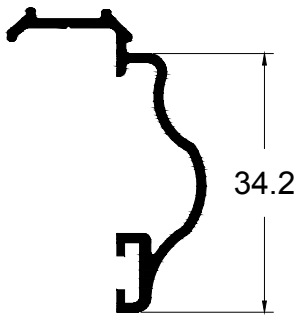

DW 12311  
0.273 Kg/m.

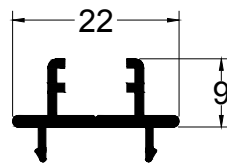

DW 12316  
0.173 Kg/m.

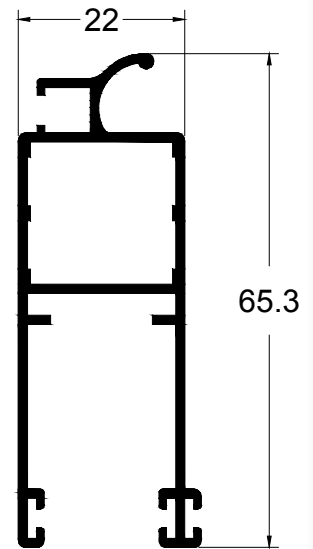



DW 12315  
0.655 Kg/m.

TV200

Sliding System

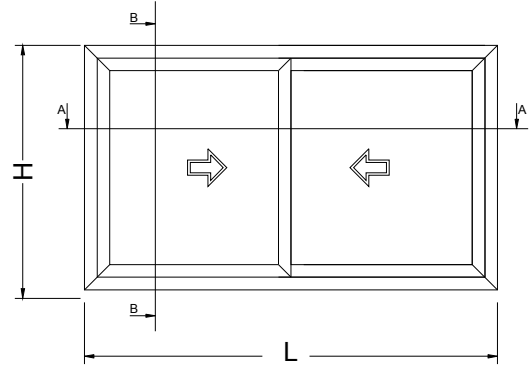
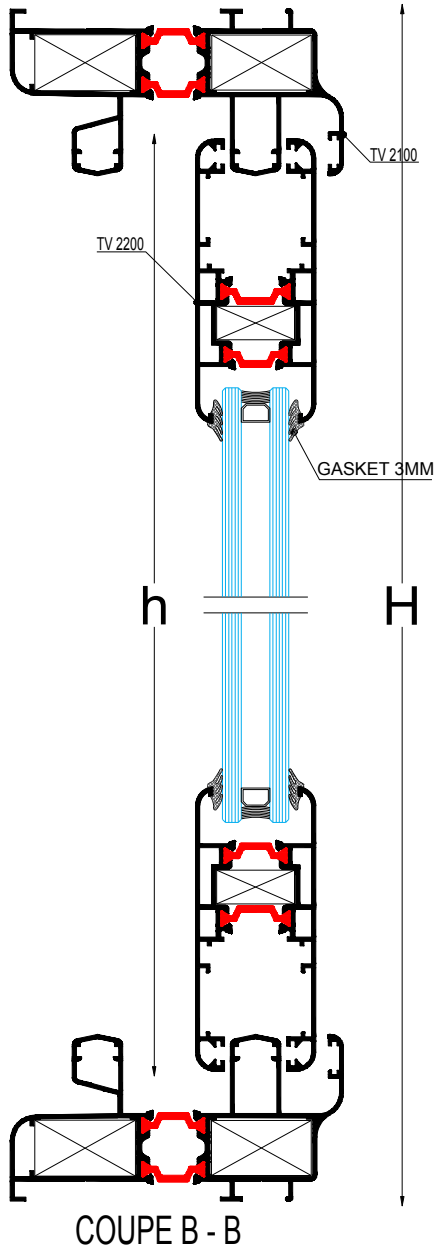
## Fenêtre Coulissante 2 Feuilles

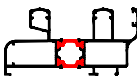
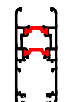

| CUTTING LIST  |            |      |                     |
|---|------------|------|---------------------|
| Shape   | Prof. No   | QTY. | CUTTING LENGTH (mm) |
|   | TV 2100    | 2    | L                   |
|   |            | 2    | H                   |
|  | TV 2200    | 4    | $\frac{L-5}{2}$     |
|   |            | 4    | H - 85              |
|  | DW 12312/A | 2    | H - 85              |
| GLASS   |            | 2    | $\frac{L - 312}{2}$ |
|   |            |      | H - 236             |

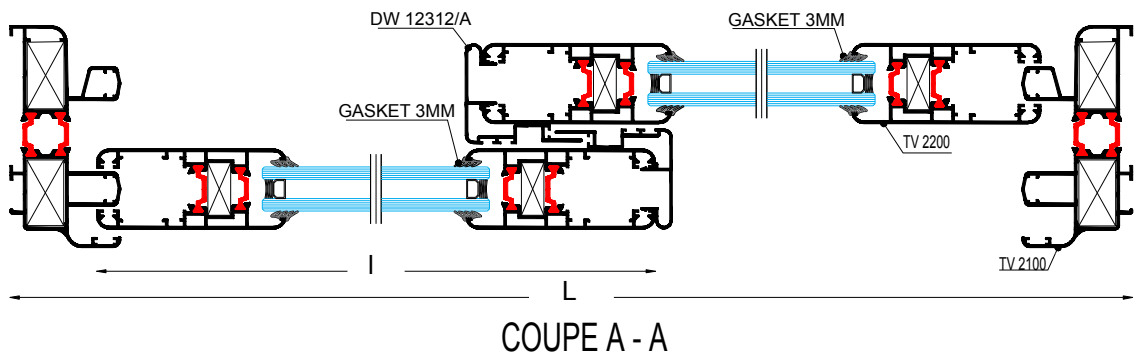



## Fenêtre Coulissante 2 Feuilles

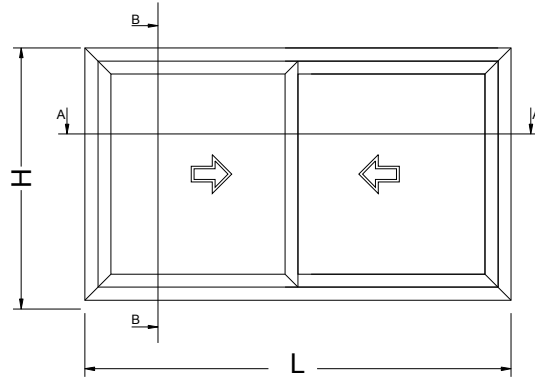
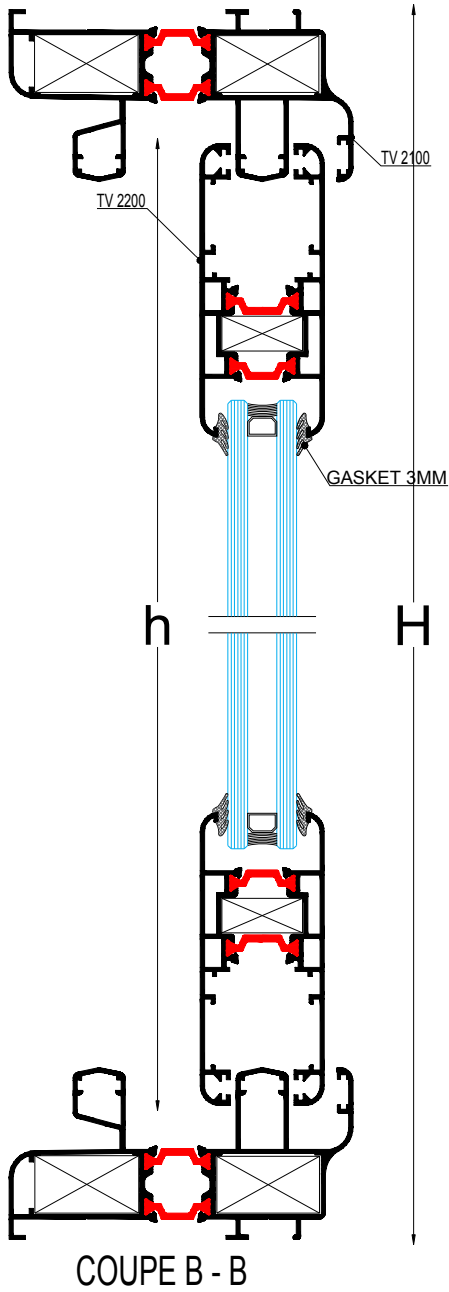

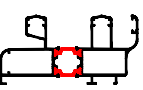
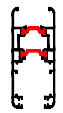
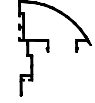
| CUTTING LIST  |            |     |                     |
|---|------------|-----|---------------------|
| Shape   | Prof. No   | QTY | CUTTING LENGTH (mm) |
|   | TV 2100    | 2   | L                   |
|   |            | 2   | H                   |
|  | TV 2200    | 4   | $\frac{L-21}{2}$    |
|   |            | 4   | H - 85              |
|  | DW 12313/A | 2   | H - 85              |
| GLASS   |            | 2   | $\frac{L - 324}{2}$ |
|   |            |     | H - 236             |

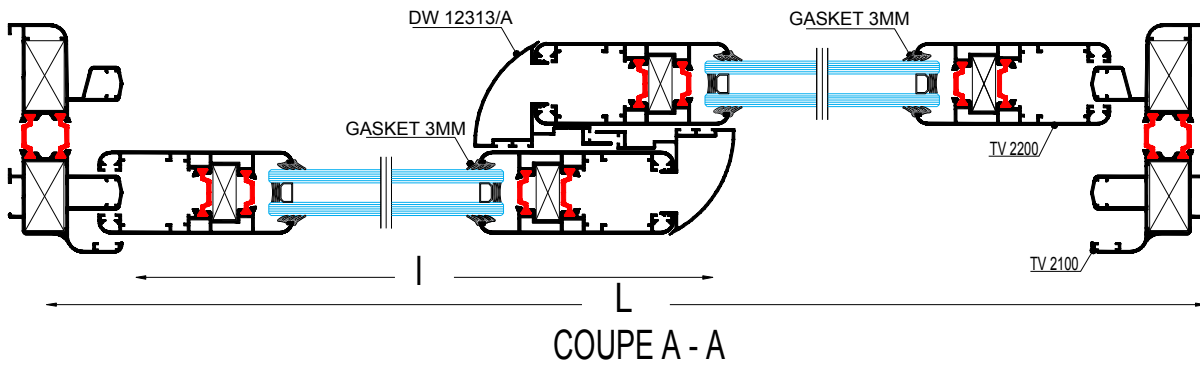

TV200

Sliding System

## Fenêtre Coulissante 3 Feuilles

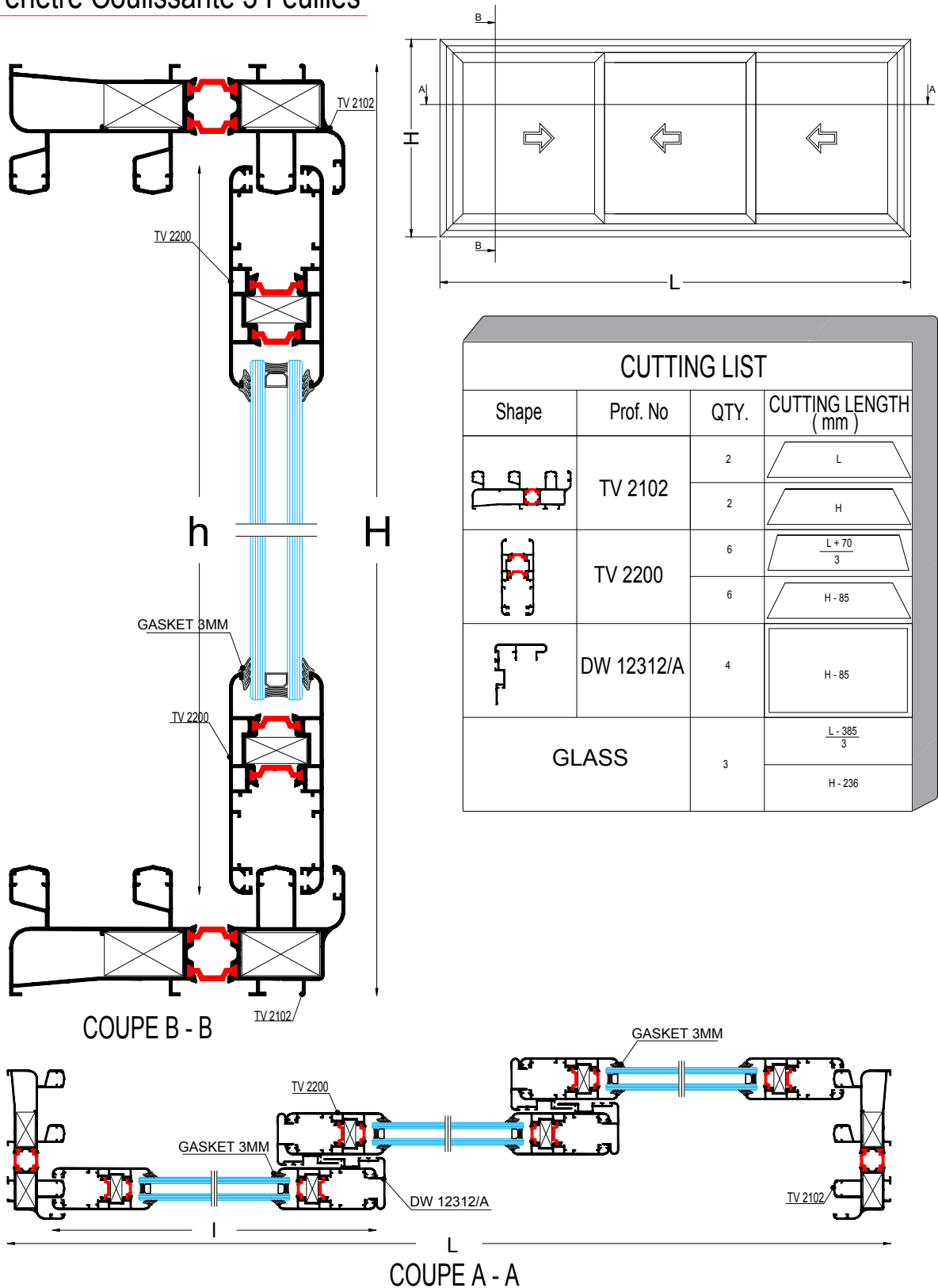

## Fenêtre Coulissante 3 Feuilles

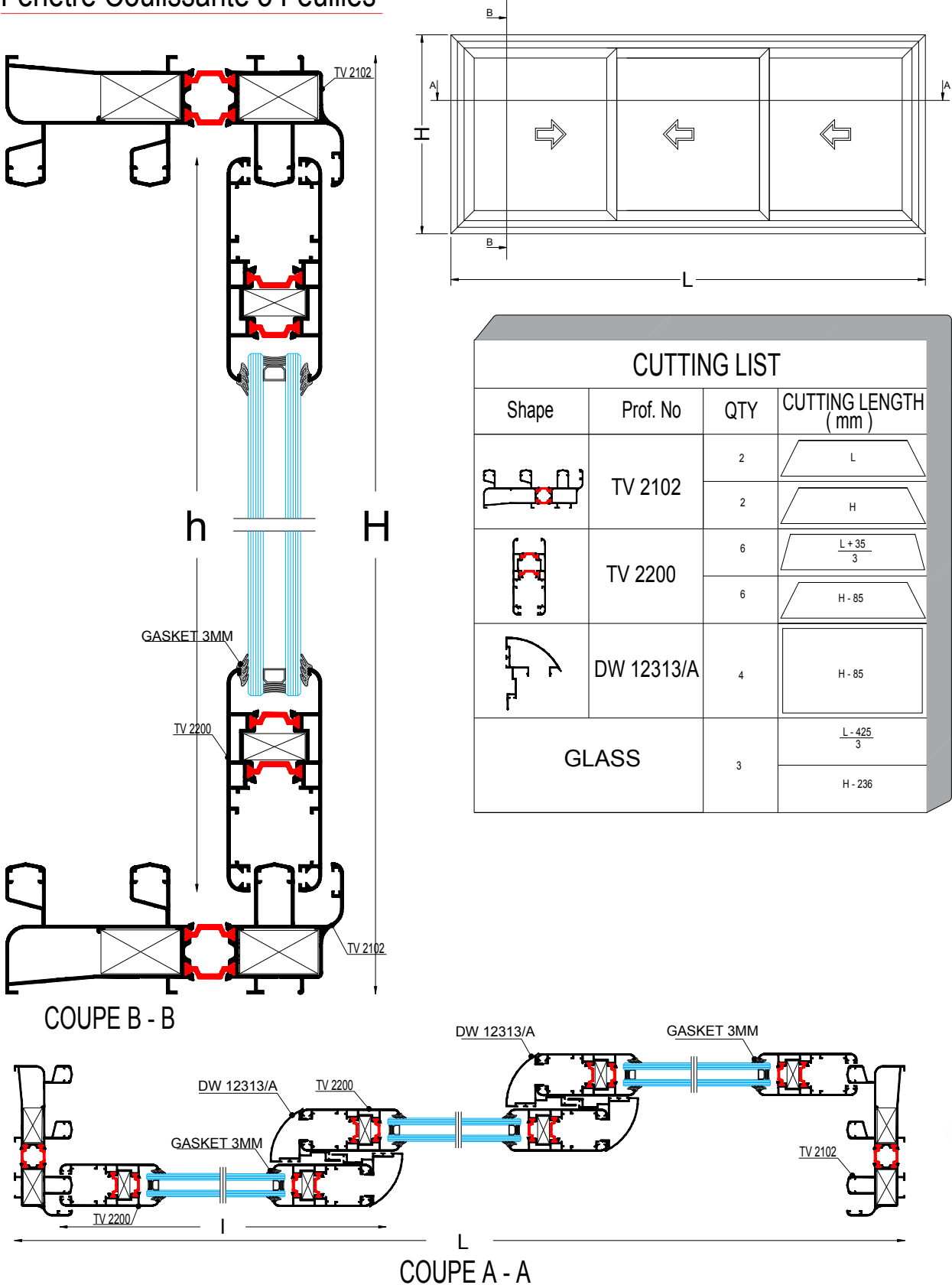

TV200

Sliding System

## Fenêtre Coulissante 4 Feuilles

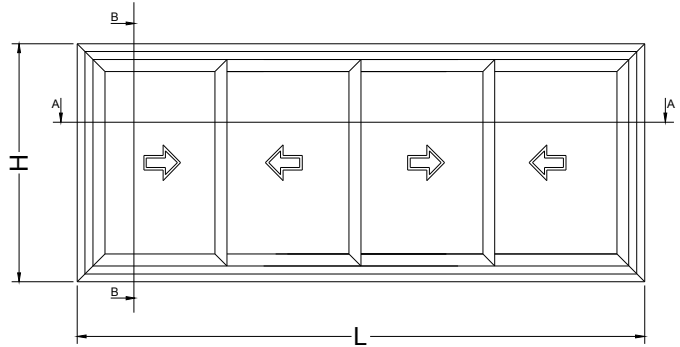
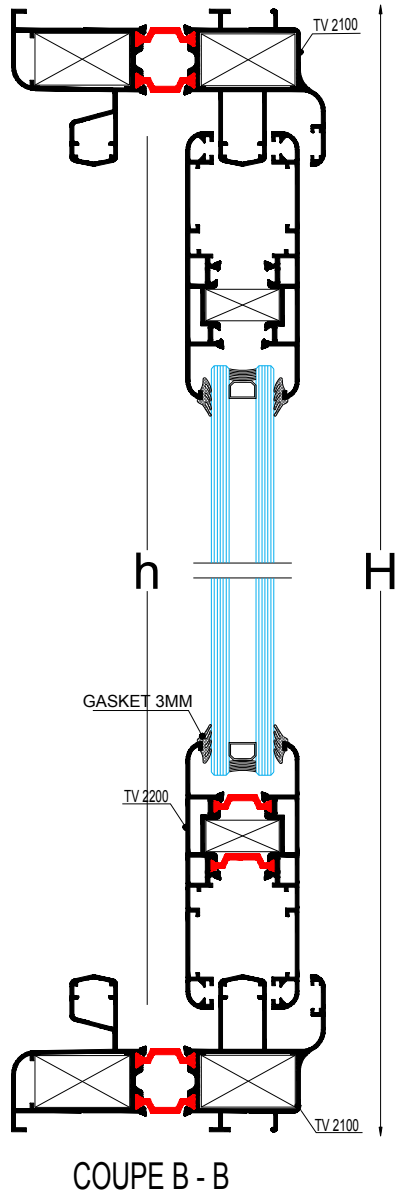

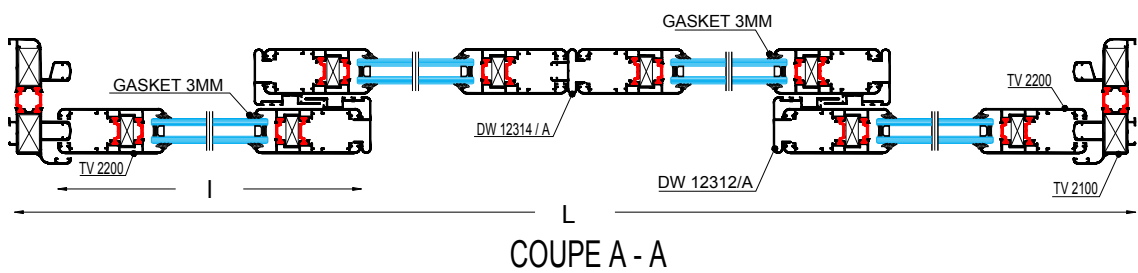

| CUTTING LIST |              |      |                     |
|--------------|--------------|------|---------------------|
| Shape        | Prof. No     | QTY. | CUTTING LENGTH (mm) |
|              | TV 2100      | 2    | L                   |
|              |              | 2    | H                   |
|              | TV 2200      | 8    | $\frac{L + 66}{4}$  |
|              |              | 8    | H - 85              |
|              | DW 12312/A   | 4    | H - 85              |
|              | DW 12314 / A | 1    | H - 85              |
| GLASS        |              | 4    | $\frac{L - 540}{4}$ |
|              |              |      | H - 236             |

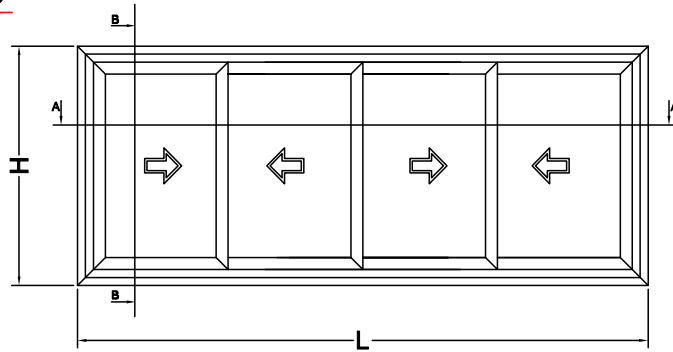
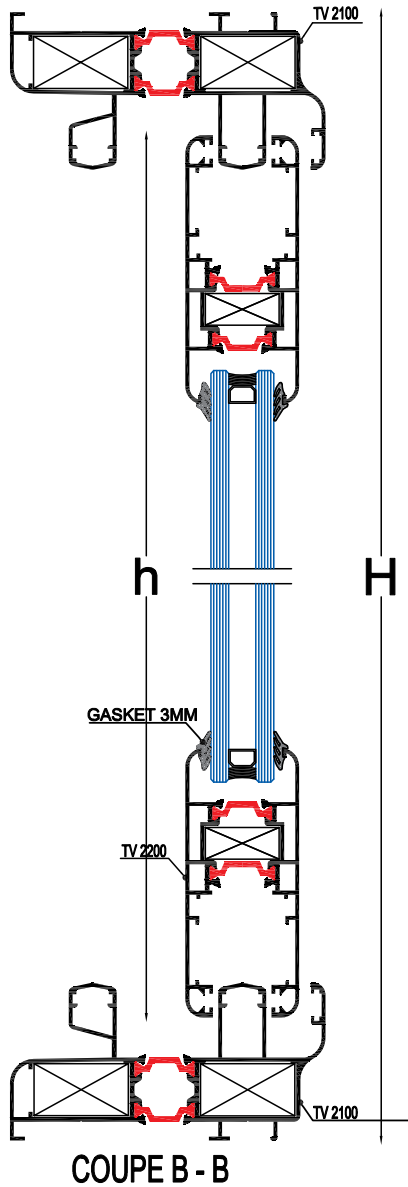

## Fenêtre Coulissante 4 Feuilles

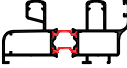
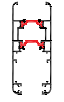

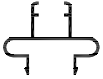
| CUTTING LIST  |              |      |                     |
|---|--------------|------|---------------------|
| Shape   | Prof. No     | QTY. | CUTTING LENGTH (mm) |
|   | TV 2100      | 2    | L                   |
|   |              | 2    | H                   |
|  | TV 2200      | 8    | $\frac{L + 35}{4}$  |
|   |              | 8    | H - 85              |
|  | DW 12313/A   | 4    | H - 85              |
|  | DW 12314 / A | 1    | H - 85              |
| GLASS   |              | 4    | $\frac{L - 580}{4}$ |
|   |              |      | H - 236             |

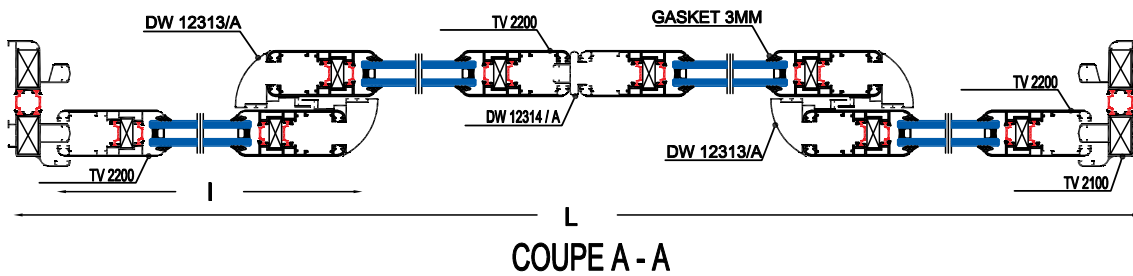



TV 200

Sliding System

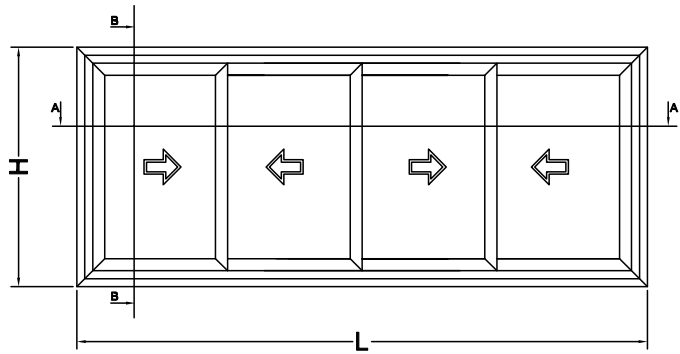
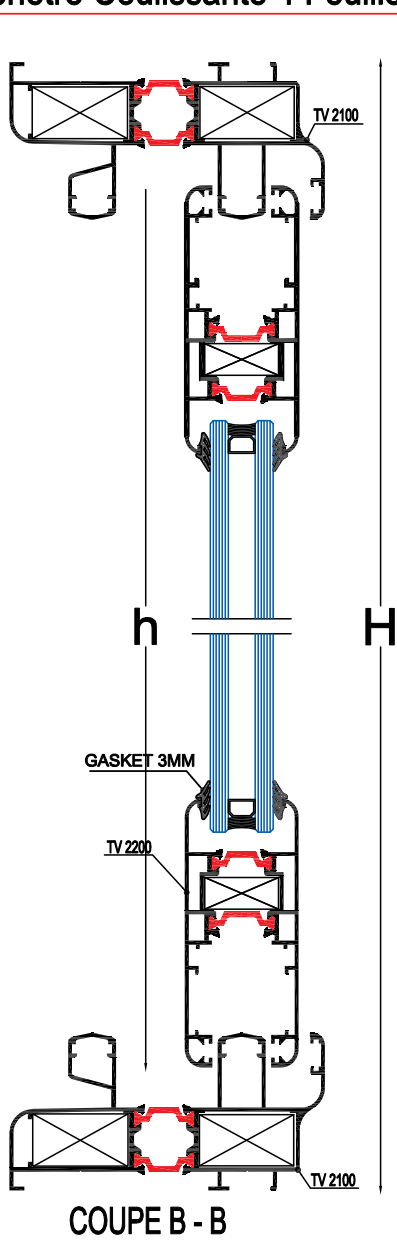
## Fenêtre Coulissante 4 Feuilles

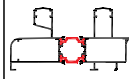
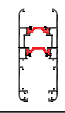

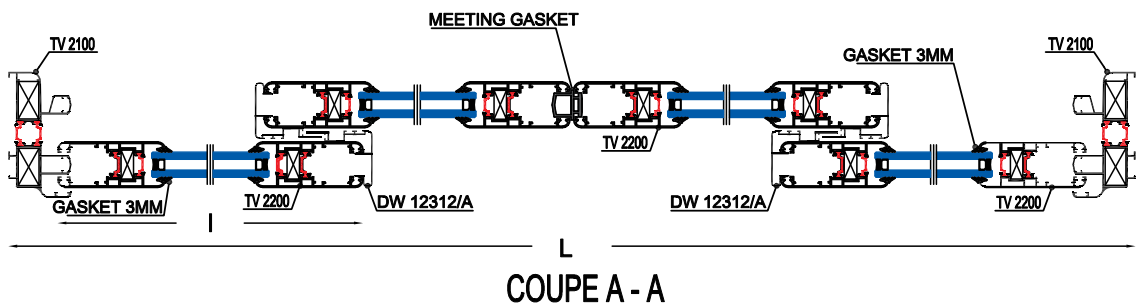

| CUTTING LIST  |            |      |                     |
|---|------------|------|---------------------|
| Shape   | Prof. No   | QTY. | CUTTING LENGTH (mm) |
|   | TV 2100    | 2    | L                   |
|   |            | 2    | H                   |
|  | TV 2200    | 8    | $\frac{L + 66}{4}$  |
|   |            | 8    | H - 85              |
|  | DW 12312/A | 4    | H - 85              |
|  | AVR.111    | 1    | H - 85              |
| GLASS   |            | 4    | $\frac{L - 540}{4}$ |
|   |            |      | H - 236             |

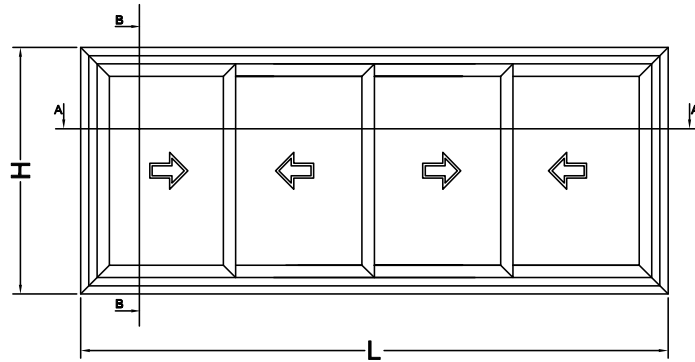
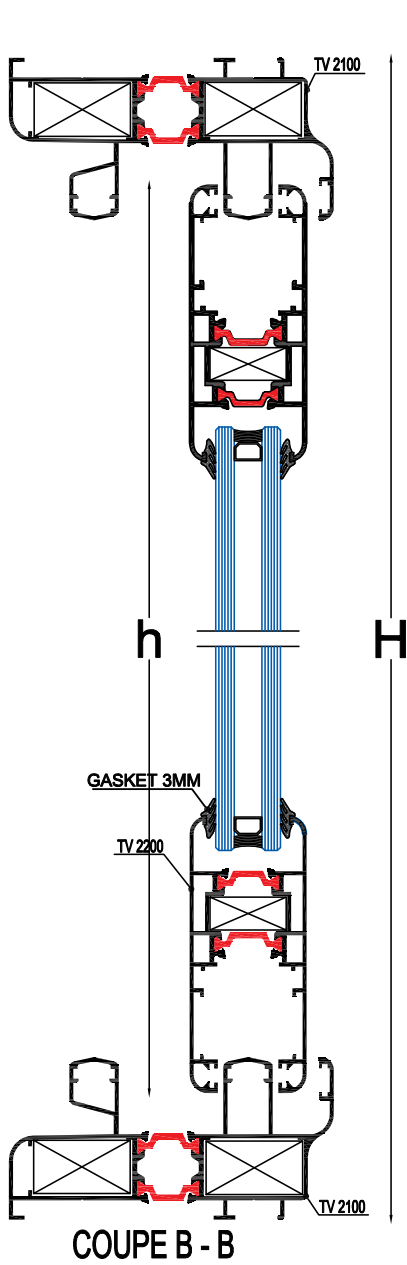

## Fenêtre Coulissante 4 Feuilles

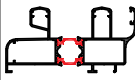
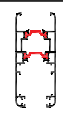

| CUTTING LIST  |            |      |                     |
|---|------------|------|---------------------|
| Shape   | Prof. No   | QTY. | CUTTING LENGTH (mm) |
|   | TV 2100    | 2    | L                   |
|   |            | 2    | H                   |
|  | TV 2200    | 8    | $\frac{L + 35}{4}$  |
|   |            | 8    | H - 85              |
|  | DW 12313/A | 4    | H - 85              |
|  | AVR.111    | 1    | H - 85              |
| GLASS   |            | 4    | $\frac{L - 580}{4}$ |
|   |            |      | H - 236             |

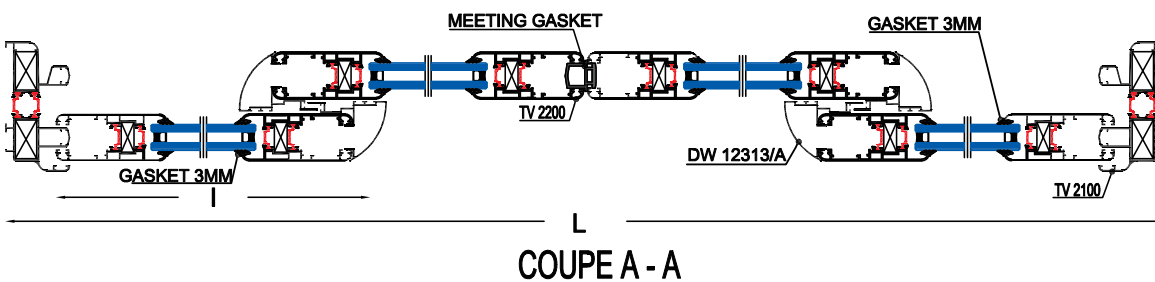

TV200

Sliding System

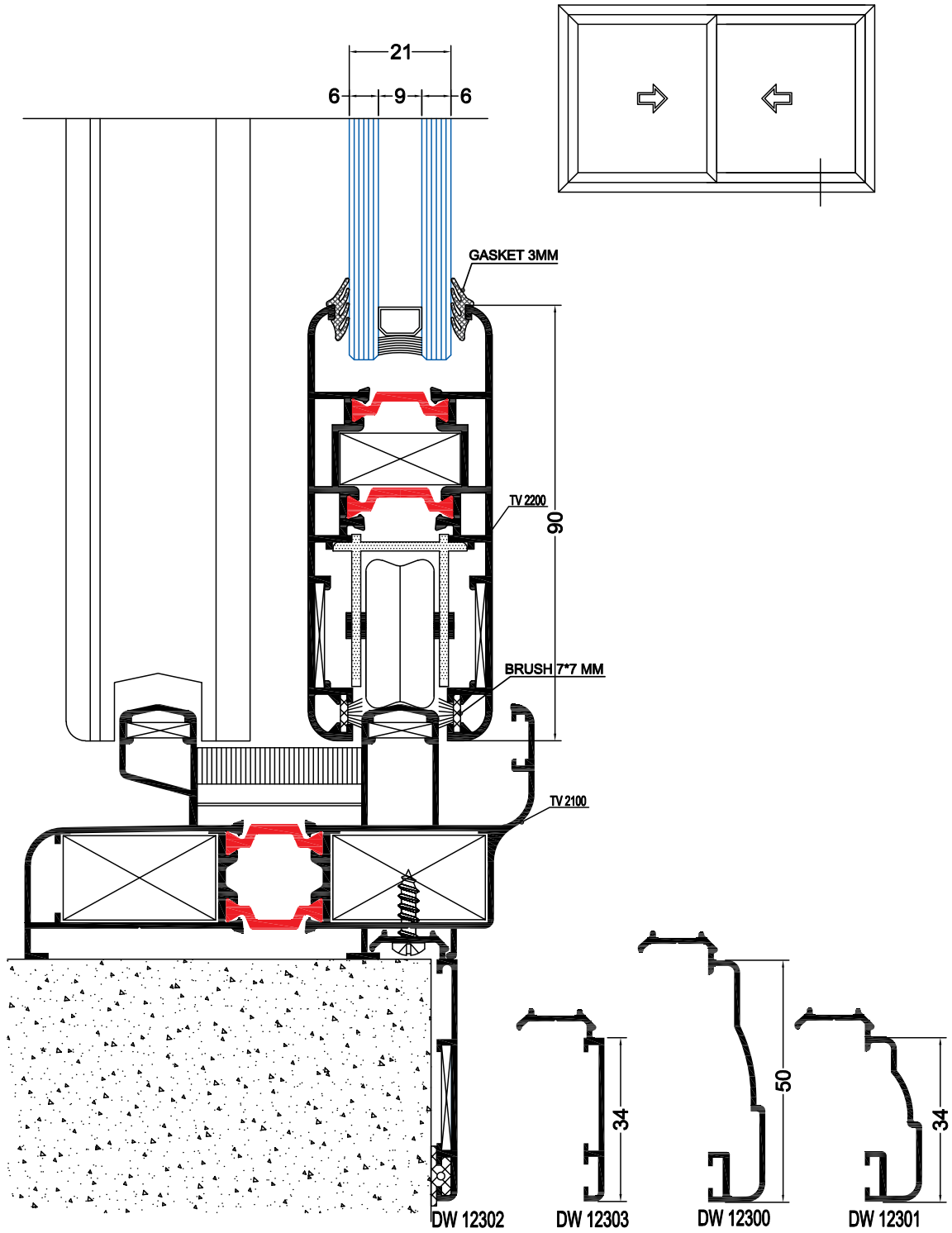

Sliding System

TV200



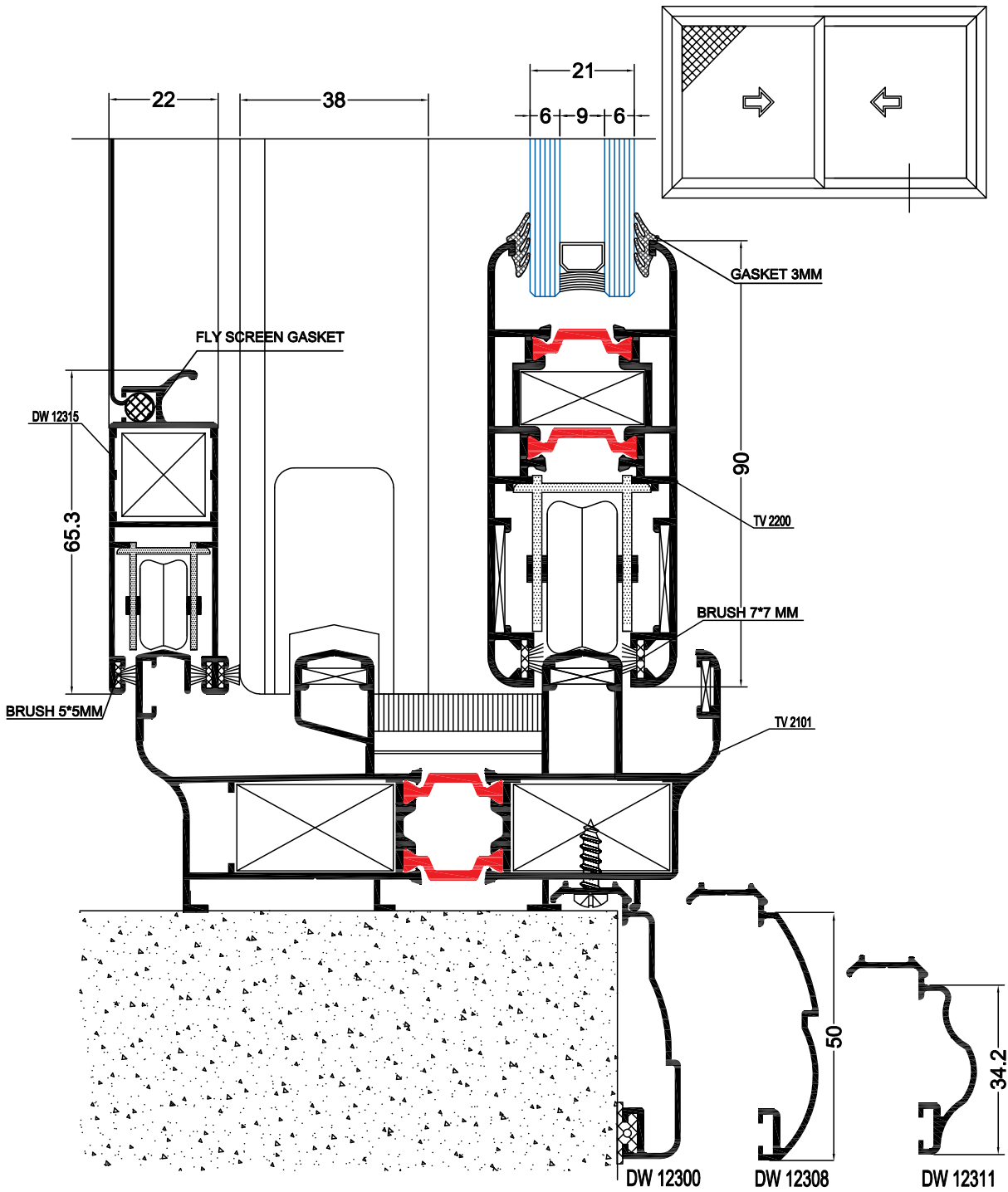

TV 200

Sliding System

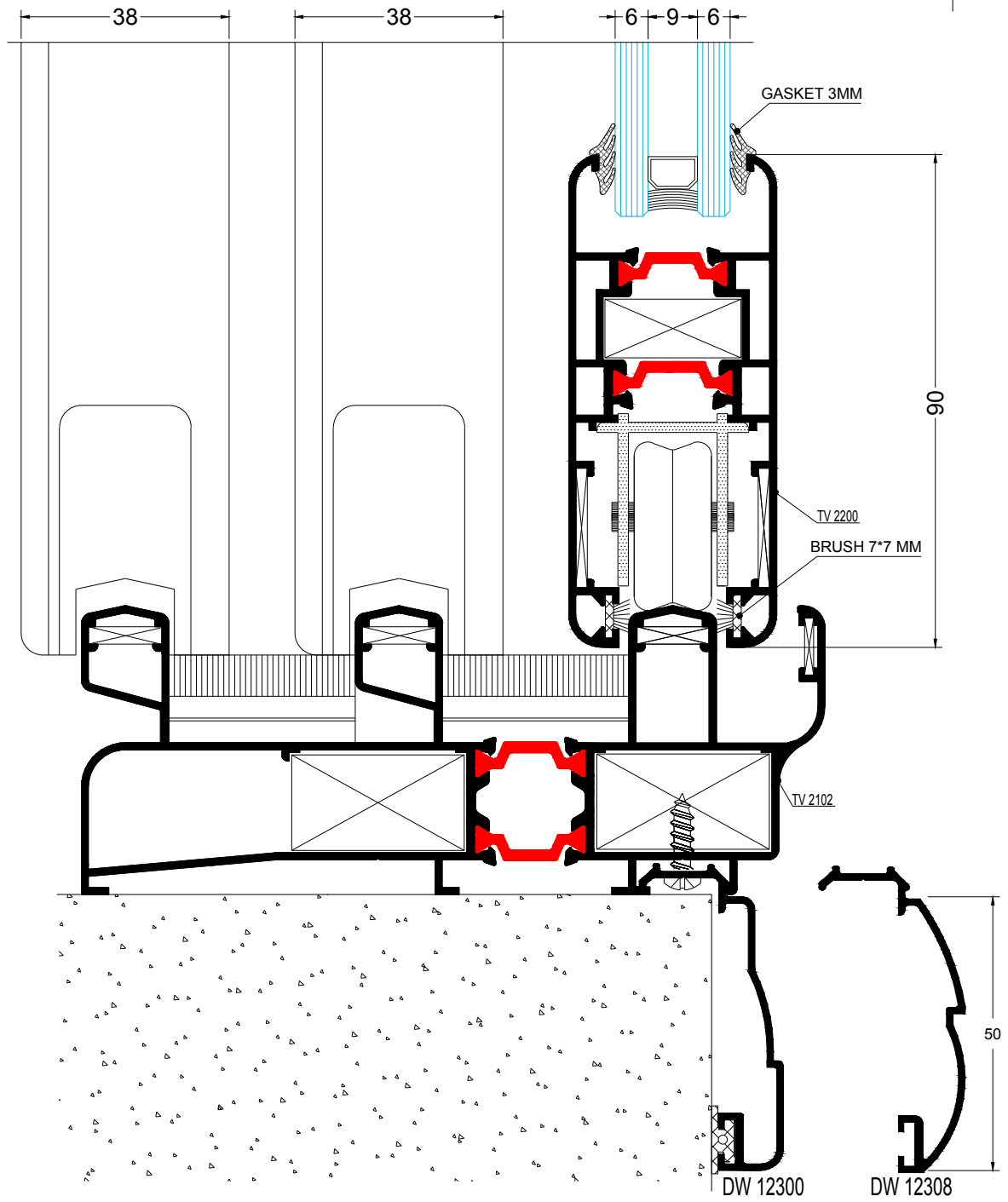
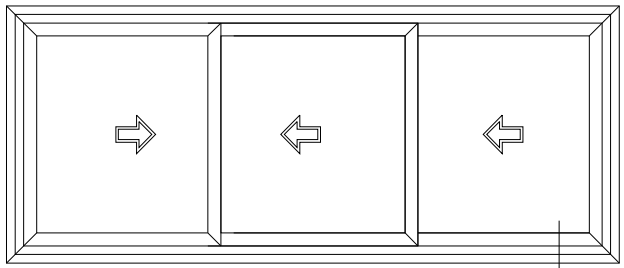

Sliding System

TV200

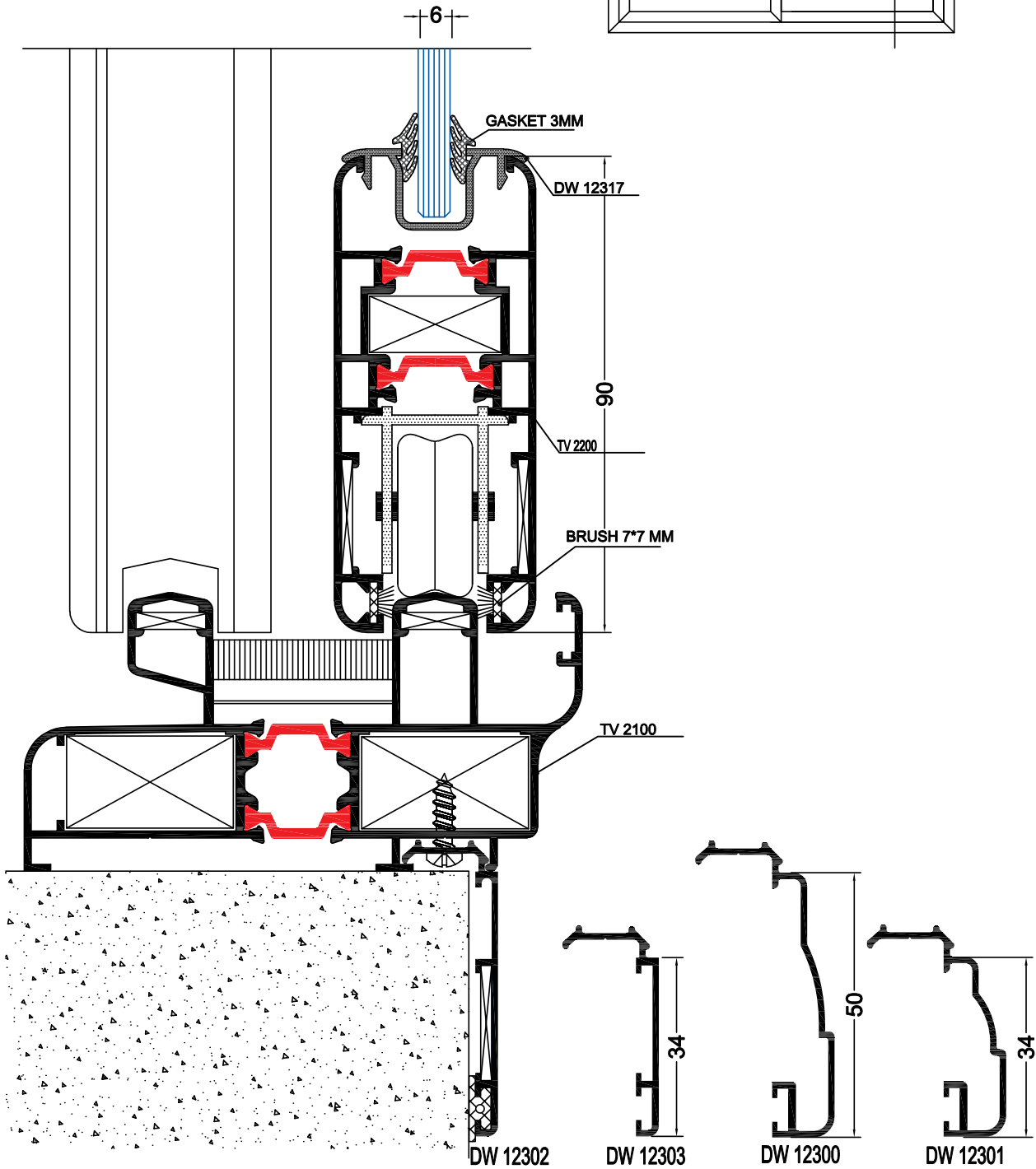
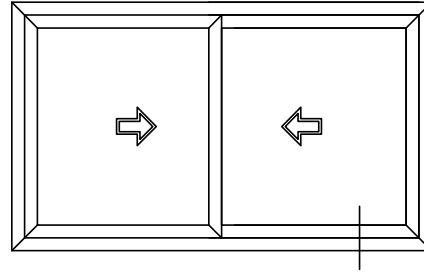

TV 200

Sliding System

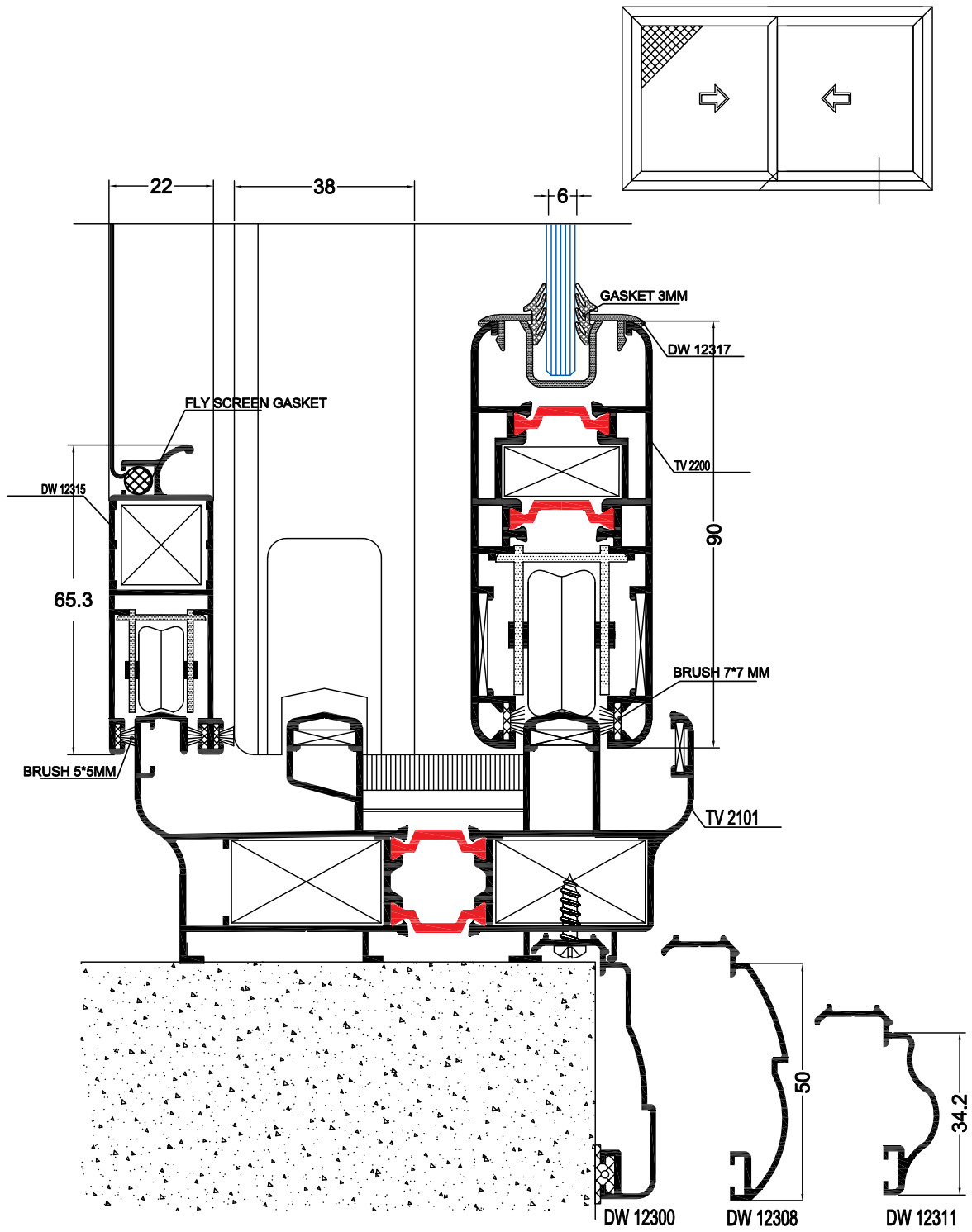

Sliding System

TV200

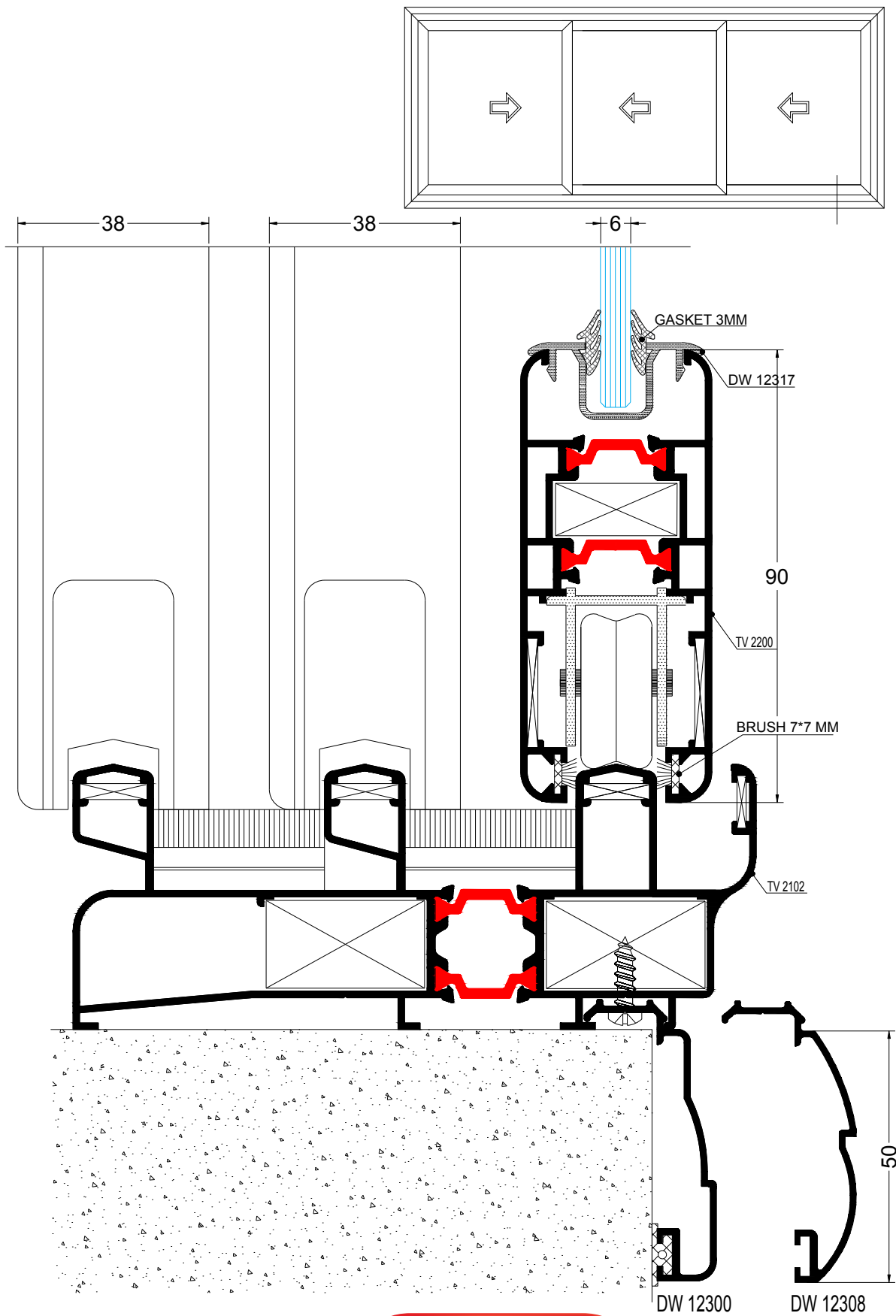

TV 200

Sliding System

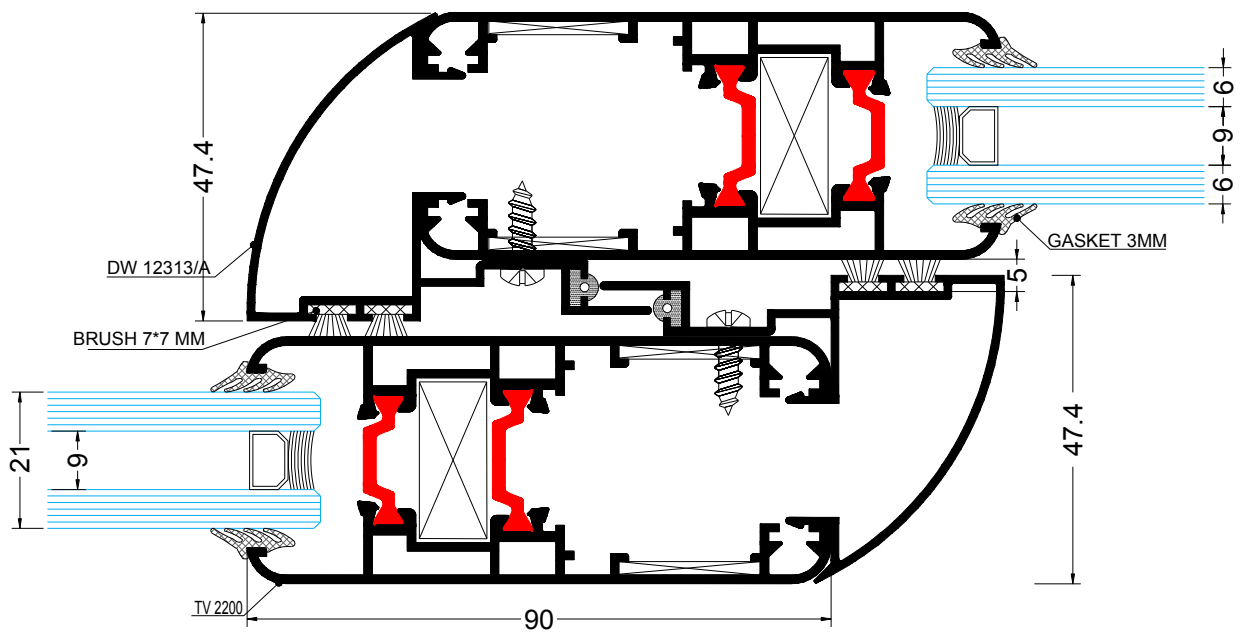
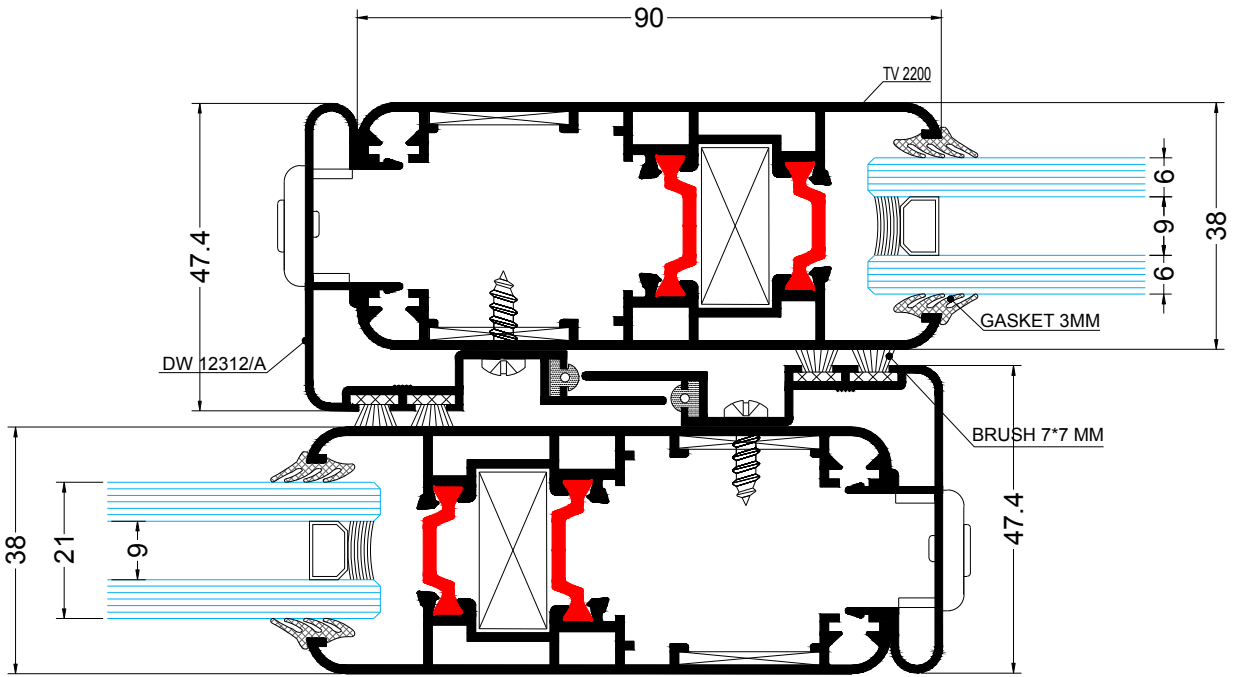
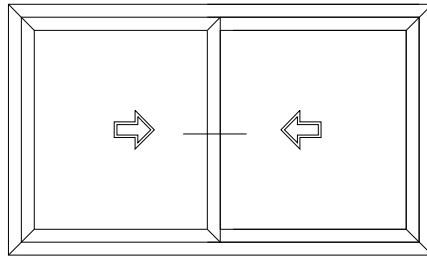

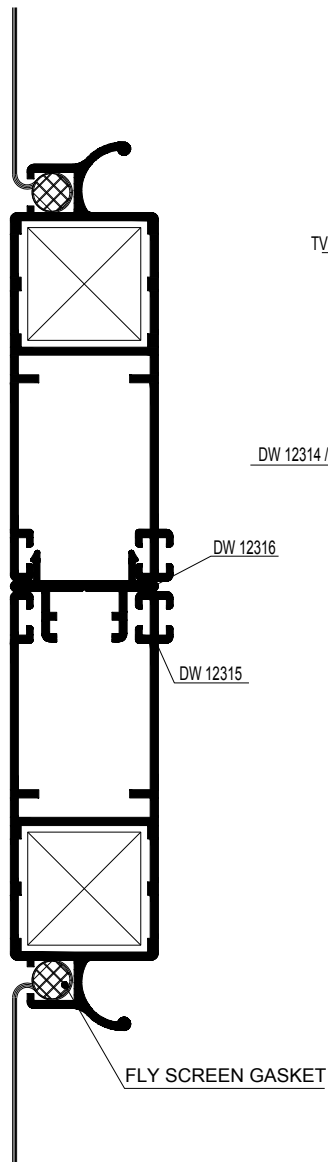
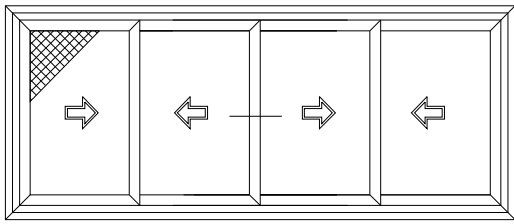

TV 2200

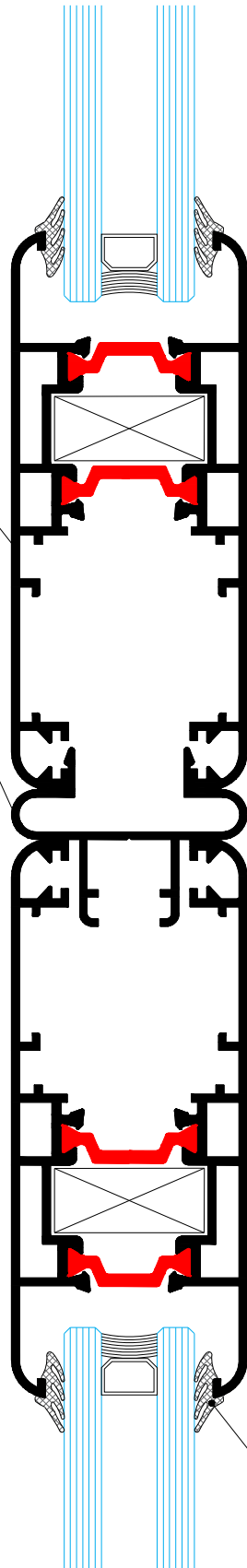

MEETING GASKET

TV 2200

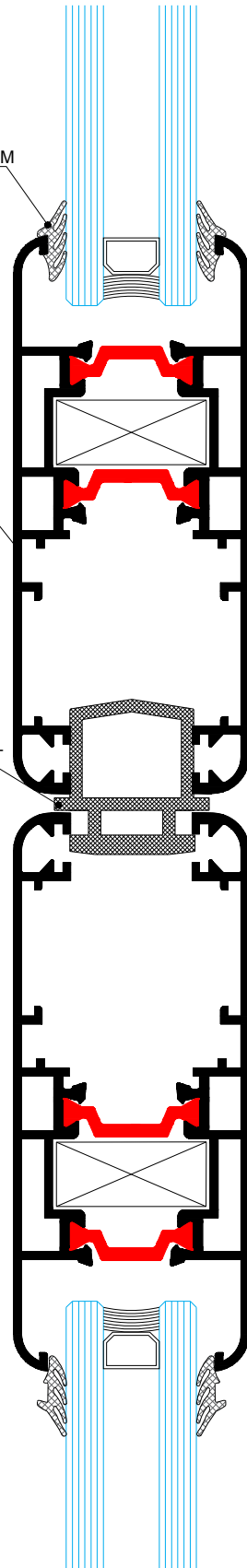

TV200

Sliding System

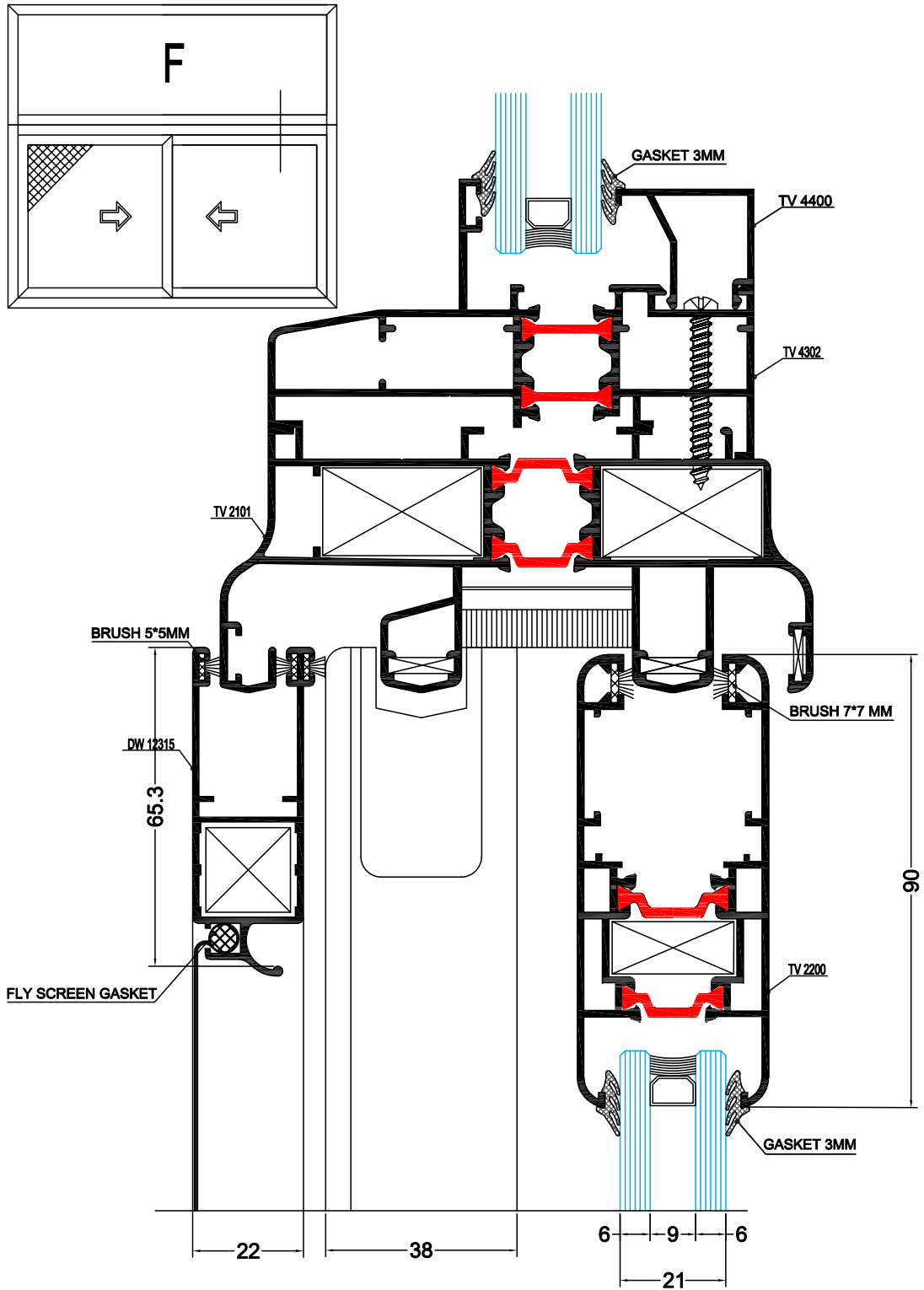

Sliding System

TV200



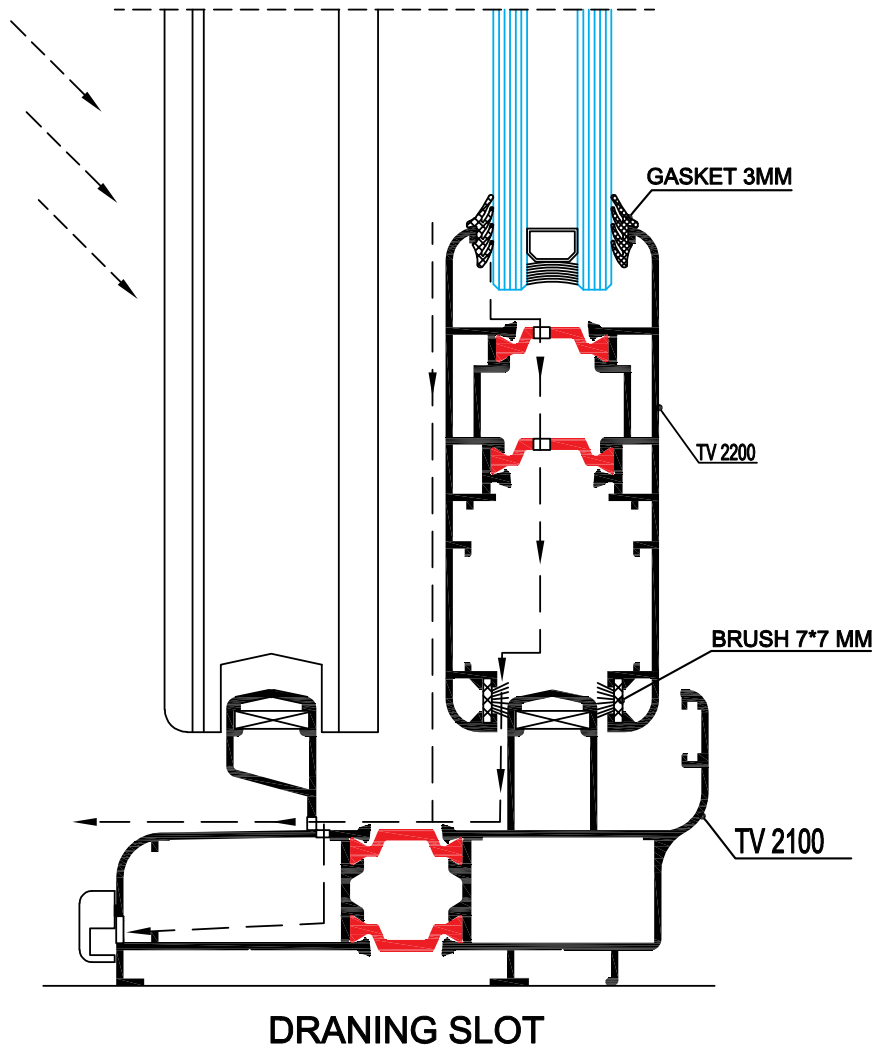

TV200

Sliding System

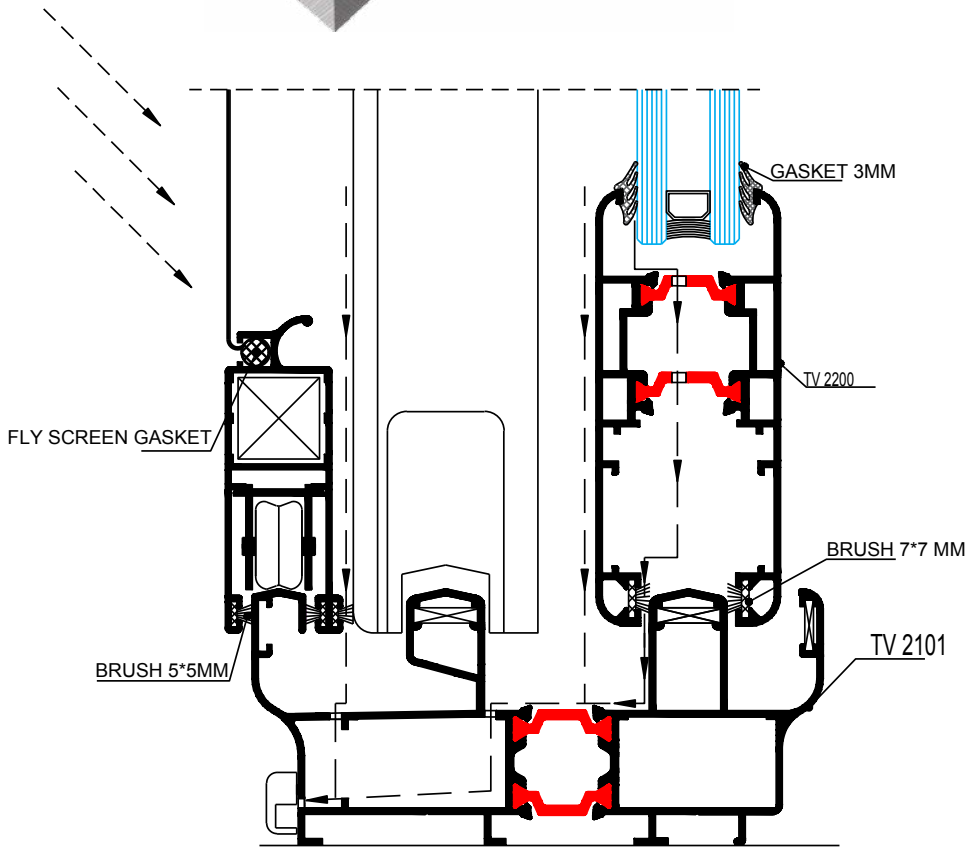

DRANING SLOT

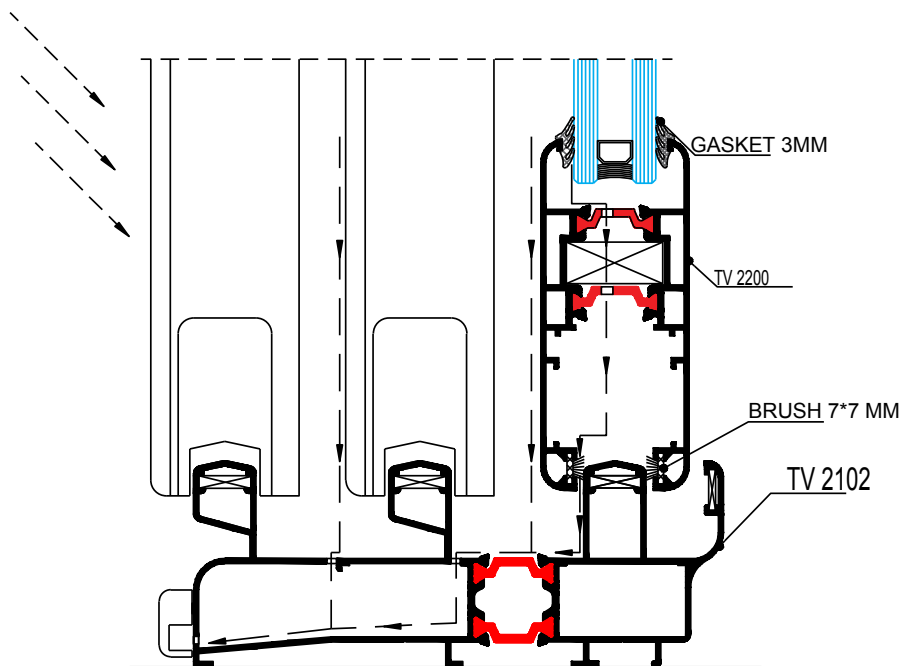

DRANING SLOT



TV200

Sliding System

